

TIRANA ARCHITECTURE
TRIENNALE



UNIVERSITETI
BARLETI

NEW
TEM
PO
RALITY



Co-funded by
the European Union

LINA

TIRANA ARCHITECTURE
TRIENNALE



Saimir Kristo, Etleva Dobjani, Gerdi Papa

FUTURE INTELLIGENCE IN ARCHITECTURE & DESIGN

Spatial Futures: Architectural Responses to Urban Transformation

FUTURE INTELLIGENCE IN ARCHITECTURE AND DESIGN
Spatial Futures: Architectural Responses to Urban Transformation

Authors: Prof. Asoc. Ph.D. Saimir Kristo, Prof. Asoc. Ph.D. Etleva Dobjani, Ph.D. Gerdi Papa

Literary Editor: Alma Gjoni

Publication and Design Preparation: Iris Nela, Erika Gashi

Cover Design: Iris Nela

Scientific Reviewers: Prof. Dr. Jorge Correia, Prof. Dr. Esen Gökçe Özdamar

Scientific Advisors: Prof. Asoc. Dr. Vera Bushati, Prof. Asoc. Dr. Laura Shumka

Publisher: dpr-barcelona

Tirana, May 2025

© 2024-2025 the authors for their texts and images

This publication is part of the Tirana Architecture Triennale organized by Architecture Fund in Albania & BARLETI University, supported in part by LINA Community Platform, the New Temporality Platform and co-funded by the European Union.

No part of this publication may be used or reproduced in any manner without written permission from the publisher, except in the context of reviews.

Printed by: dpr-barcelona

ISBN: 978-84-128922-7-7

This book is set in Tw Cen MT.

Printed on Semi Mat 115g paper/Coated Paper 300g

Generated with Print on Demand Technology



CONTENTS

10 Foreword

14 **Edition 1_Volume I**
Virtually Present, Physically Invisible

54 **Volume II**
Permanent Temporalities

122 **Volume III**
Reflection

122 **Edition 2_Volume IV**
Architectures of the Invisible

160 Conclusions

192 Bibliography

FUTURE INTELLIGENCE IN ARCHITECTURE & DESIGN

Spatial Futures: Architectural Responses to Urban Transformation

Saimir Kristo, Etleva Dobjani, Gerdi Papa

VIRTUALLY
PRESENT,
PHYSICALLY
INVISIBLE.

foreword

Tirana Architecture Triennale is a non-profit activity organized by the Architecture Fund in Albania and BARLETI University with the mission to question and research, develop and structure, and manifest architectural thinking, debate and reflection. Itself is organized as a diptych of a triennial and a trilogy at the same time. Tirana Architecture Triennale is revealed to the public in its opening year with a statement, followed next by its critical distance and finally concluding during the third year with its reflection epilogue.

The origin of Tirana Architecture Triennale, unfolds in the Albanian context, three decades, still in its transition state. Socially, culturally and architecturally. Yet, it does not limit itself to Albania as a point of reference rather as a point of reflection.

Forsooth, beyond all geographic and disciplinary boundaries, we find ourselves in another state of transition; from the Holocene towards the Anthropocene, from the analogue to the digital, and from the physical to the virtual.

mission

Open to its form and format, Tirana Architecture Triennale operates in a constructive dialogue with the city of Tirana; academia, cultural institutions and collectives, independent groups and the Association of Albanian Architects as the main actors of this dialogue in addition to the citizens of the city themselves.

The mission of Tirana Architecture Triennale is;

- to create a coherent response to architectural and urban development in Albania.
- elaborately unfold each edition into three volumes, while acting through a plural curatorship in each edition.
- to act as an open platform of independent thinking promoting national and international architecture.
- engage local students, young architects, urban designers, planners, artists, professionals and community into the contemporary debate on living habitat.
- produce content of excellence through lectures, workshops, exhibitions, public installations, published work and competitions.
- to nurture an urban living laboratory for the city; through theory, experimentation and practice.
- to establish a center for architecture in Tirana and Albania part of European and International networks, stimulating and promoting the city's values.

Tirana Architecture Triennale is organized in collaboration with the Architecture Fund in Albania and BARLETI University in Tirana, the Faculty of Applied Sciences and Creative Industries; a school for independent thinking in architecture, design, analogue and digital mediums and the Architecture Fund of Albania.



TIRANA ARCHITECTURE
TRIENNALE

[Scribbled text]

[Scribbled text]

virtually present, physically invisible

first volume
Tirana Architecture Triennale Vol. I

The topic “Virtually Present, Physically Invisible” examines how urban and interior spatial experiences have changed in the digital age and in the aftermath of pandemics. The tension between virtual presence and physical absence is explored across metropolitan settings, home environments, and hybrid public–private interfaces that have undergone rapid transformation through technology and social isolation.

At the heart of the chapter is the way the inhabited interior (domus) has been repurposed as a public platform—serving simultaneously as office, classroom, and social lounge—and thus collapsing the traditional divide between civic space and private refuge. Meanwhile, metropolitan streets, plazas, and transit hubs were emptied and reprogrammed as stages of surveillance and desolation, where physical bodies gave way to avatars on video calls, posts on social media, and endless camera feeds.

Technology now allows a body to act, speak, and engage without ever setting foot in a shared space. This fundamental shift carries profound implications for architecture and urban planning: hybrid environments emerge—part digital overlay, part material substrate—while questions arise about the value of touch, co-presence, and the sensory richness of unmediated space.

Globalization and Space-Time Compression

The dissolution of physical barriers through globalization accelerates these dynamics. As capital, information, and people circulate more freely across borders, the distinction between “here” and “there” becomes blurred. Architecture no longer serves only a local community but a global audience—drawn, for example, to digitally curated co-working spaces that bring together remote workers scattered across continents. space-time compression (Harvey, 1989) intensifies our sense of simultaneity, even as it undermines deep attachments to any single place.

Migration, Translocality, and Diaspora

Parallel to digital mobility, human migration creates translocal communities that straddle multiple physical and virtual places. Migrant workers, refugees, and diaspora maintain connections to distant homelands via video calls, social media networks, and virtual rituals, crafting liminal spaces in their apartments that mirror far-off streets, markets, and communal gatherings. These digital-hybrid dwellings challenge architects to design interiors that accommodate both the longing for rootedness and the realities of transience.

Digital Transformation and Network Society

The rise of the network society (Castells, 1996) and concepts of networked individualism (Wellman & Rainie, 2012) foreground how social ties now rely on digital infrastructures rather than proximate co-presence. Smart home technologies, IoT sensors, and augmented-reality overlays modulate our spatial perceptions—windows become live feeds of distant events, walls display ever-shifting data, and floors sense footsteps to trigger adaptive lighting. Architecture must now negotiate between physical thresholds and virtual portals, creating seamless transitions that preserve a sense of continuity.

Non-Places and Loss of Sense of Place

Marc Augé's non-places (1995)—airports, highways, shopping malls—have proliferated into every corner of our built environment. Their placeless anonymity, once tolerated for brief transits, now extends into daily life as shopping apps mimic mall displays, and remote work turns dining tables into conference rooms. This placelessness erodes the emotional bonds that underpin community and belonging, raising the challenge: how can design re-infuse soul into spaces that have become mere backdrops to digital interaction?

Reclaiming Place through Multiscalar Interventions

To counteract these tendencies, scholars and practitioners draw on theories of topophilia (Tuan, 1974) and genius loci (Norberg-Schulz, 1979) to re-anchor architecture in local climate, culture, and material heritage—even as interiors serve as nodes in global networks. Pop-up installations, ephemeral urban interventions, and participatory design workshops invite inhabitants to co-create place-making rituals that stitch digital layers into the physical fabric, restoring a measure of rootedness.

Evolving Concepts of Presence and Belonging

Ultimately, “Virtually Present, Physically Invisible” reframes presence as a spectrum—from the fully embodied to the entirely digital—and asks architects and planners to reconceive spatial design around flows of people, data, and memory. In a world where home, office, school, and café can collapse into a single app-mediated envelope, the task becomes to weave together migrations both human and virtual, to forge hybrid places that honor sensory richness, enable social bonds, and cultivate a resilient sense of community and belonging across multiple scales of experience.

The Missing Bodies – Architecture of Virtual Presence and Physical Disappearance.

In March 2020, a new era of spatial experience began, one that was both closed and protracted, close and distant, and internal and visible to the public. Human movement was restricted and cities were physically locked down, which caused a fundamental change in how we connect with one another and with space. All at once, the living room, kitchen, or private studio became the backdrop of everyday public life, transforming into workplaces, classrooms, galleries, meeting spaces, and even sites of solidarity or protest. This significant change brought to light a fresh conflict between the digital and corporeal selves. Someone who lives in an urban area but is physically invisible has become a new type of urban resident.

Rather than directly experiencing urban spaces, we started to see them through screens, microphones, transmitted images, and compressed sound. Architecture had to deal with the contradiction of presence via disappearance and the absence of the body since it was constantly linked to material sense, scale, light, and movement.

Through the prisms of architectural theory, technology, and urban practice, this chapter seeks to evaluate this experience. Through a combination of theoretical analysis and real-world examples, we will investigate how architecture mediates virtual presence and how this has profoundly impacted ideas of control, intimacy, privacy, and the public. The fundamental query at the center of this contemplation is: What happens to architecture when the body is no longer there yet nevertheless presents itself as present?

The Interior Space as a Public Stage: An Architectural and Foucauldian Analysis

This significant change exposed a fresh conflict between the digital presence and the physical body. An entirely new class of urban dwellers has arisen: those who are physically unseen yet virtually present. We started to inhabit the city through the screen, the microphone, the broadcast image, and the compressed sound rather than directly experiencing it through bodily presence. Architecture, which has always been associated with materiality, size, light, and movement, has to deal with the contradiction of visibility via disappearance as well as the absence of the body. The purpose of this chapter is to examine this experience from the perspectives of urban practice, architectural theory, and technology. We analyze how architecture transmits virtual presence and how this has profoundly impacted ideas of privacy, publicity, intimacy, and control by fusing theoretical thoughts with real-world instances. What happens to architecture when the body is no longer there but yet projects itself as present? This is the central question at the heart of this reflection.

The Interior as a Public Arena

People's perceptions and uses of space, especially interior space, have changed significantly as a result of the COVID-19 epidemic. A different kind of exposure happened through technology: the screen became the new means of participation, socializing, and working, while physical distancing separated the body from conventional public areas like streets, auditoriums, or plazas. This change was a paradigmatic act that changed the way architecture is experienced in daily life, not just a short-term reorganization of functions.

In this case, the interior space—which was formerly a private and intimate realm—became a stage for public performances. Like a stage in a play, it became the place where people showcased themselves—not in the office or on the street, but via the camera and microphone.

Personal libraries, kitchens, and rooms were converted into multipurpose spaces with overlapping identities. Architectural theories that examine the connection between the body, control, and surveillance are strongly resonant with this division and balancing of roles and places.

The panopticon, as discussed by Michel Foucault in his 1975 book *Discipline and Punish*, is a crucial idea in understanding this phenomenon. Jeremy Bentham first proposed the panopticon, a control device in which the subject is continuously under surveillance without ever being able to be certain that they are being watched. According to this paradigm, the effect of control is internalized, and because there is always the possibility of supervision, conduct is self-regulated (Foucault, 1975).

This concept is reversed and changed in the era of virtual communication. The person is now conscious of their visibility rather than being silently observed, but they only have some control over what is displayed. Instead of being a neutral means of transmission, the camera above the screen serves as a «new window» that serves as a point of interaction between the

interior and the exterior, replacing the architectural window's symbolic meaning as well as the practical function of natural light. Since the camera chooses, arranges, and frames the space in accordance with the principles of continuous performance, it has a different relationship with intimacy than the conventional window, which can be closed, covered, or filtered.

In this way, interior design becomes more than just scenography; it is a co-creator of social presence and identity. A «new scenography of the self» is composed of backdrop components, lighting, and objects, all of which communicate social, cultural, or professional signals. As elements of a semiology of interior architecture, a full bookcase, cozy lighting, and background artwork serve as outward manifestations of self-representation. The relationship between social control and spatial form has been frequently discussed in architectural theory, including ideas of performativity (Goffman, 1959; Lefebvre, 1991), transparency (Koolhaas, 1995), and surveillance (Foucault, 1975). Living, working, and being exposed all happened at the same time in the pandemic's internal space, which was no longer merely a physical location. It became a spatial palimpsest, where every layer, intimate, functional, public, was overlaid without clear boundaries.

A new architectural awareness was also brought about by this experience: flexible architecture that can support multifunctionality, quick transformation, and exact control over visibility is now required, as opposed to the previous emphasis on designing for distinct and specialized functions.

The virtual panopticon, with the screen at its heart, caused control to move from physical structures to digital ones, resulting in a spatial paradigm crisis as well as a health crisis. In an increasingly technologically mediated society, architecture as a discipline must face this new challenge: to design environments that are not only livable but also sensitive to new logics of visibility, self-presentation, and control.

The “Digital Window” and the Disappearance of the Physical Body

Was the pandemic a passing occurrence or a turning point for architecture and our approach to space habitation? The remnants of that era still influence how we perceive presence, transparency, and control even when walls no longer physically enclose us. The internal area is no longer only ours or protected; rather, it has evolved into a complex space where appearance and concealment coexist. The idea of being together yet separated by a screen has permeated everyday life and transformed the traditional understanding of architecture as a place of residence and embodiment.

In a world that is becoming more and more mediated by technology, architectural space is now the site of the camera rather than the body.

The Zoom or Teams window serves as a «digital window,» serving as both a façade - presenting a framed and chosen view of the user and their surroundings - and a boundary - dividing what is seen from what is out of view. The architectural act has shifted from materiality to the control of perception, with the user and technology establishing this new, invisible barrier instead of the architect.

Because of this mediated presence, the body is visible but not physical. The physical body vanishes as a genuine mass; weight, texture, and impulsive movement in a space are no longer used to sense presence or physical distance.

What’s left is a picture that serves as a simulacrum, meaning it is representative but lacks firsthand experience. In this sense, a scenographic experience - where regulated lighting, carefully chosen backgrounds, or a microphone are enough to create «space»- replaces the experience of architecture as a traditional

spatial context, which is dependent on scale, orientation, rhythm, and materiality. The notion of French philosopher Paul Virilio steps in here quite strongly. Technology's displacement of the body, he contended, is a sign of a civilization that is accustomed to the speed of information. The body is «transparent» in this reality since it is not a part of material experience and is instead a constant stream of images (Virilio, 1997).

The entire architecture of participation, including in a meeting, lecture, or conversation, now takes place on a technologically arranged interface plane rather than in the physical space one occupies. Being present yet invisible is a novel way to participate, seeing space as a filter for representation rather than a container for the body.

Furthermore, this filter isn't neutral. With some significant modifications, it is an additional visual control mechanism that carries on the reasoning of Foucault's panopticon. In contrast to earlier times when the subject was unaware that they were being watched, they now feel a silent duty to exhibit themselves, to uphold a particular scenography, and to create a version of themselves that conforms to the «digital field of vision.»

An internalized discipline, this self-control and self-curation of personal space on the screen is a close fusion of the social, psychological, and architectural (Foucault, 1977).

In the end, what started out as a short-term requirement during the pandemic has evolved into a new architectural condition that still shapes work, education, and daily life. It served as more than just a disruption; it was a test-bed for interior architecture, setting the stage for a new era of virtual space and visual control. Architecture must reconsider its function in this environment, not only as a wall-builder but also as a director of hybrid life scenarios in which perception and technology are interdependent with the body, vision, and presence.

The Interweaving of Private and Public: When the Home Becomes the City

The idea of habitation has undergone a significant transformation in the new post-pandemic environment. The house, which had been thought of for generations as a place of refuge, seclusion, and disengagement from the outside world, lost its walled walls and started to serve as an urban microcosm. Unknowingly, we began to live in an internal city where the office, school, café, creative studio, public meeting space, and digital communication street, all of which were previously obviously distinct metropolitan zones, coexisted. As a result, the traditional typology of the dwelling—which was originally thought of as a hierarchy of rooms with distinct purposes—was overloaded with several concurrent uses.

This move of urban functions inside the home represented a paradigm shift in the way space is created and viewed, not just a practical problem. The inner space is no more a neutral container but rather a network of relationships where social structure, power, economy, and technology converge to create new spatial meanings, making Henri Lefebvre's notion of space as a «social product» crucial in this regard (Lefebvre, 1991). For instance, the living room is no longer just used for family gatherings. Through the lens of the camera, professional, intellectual, and artistic identities are performed on this stage of public life. Under this scenario, the background becomes more significant than the speaker. The object, lighting, wall color, or book placed casually behind the shoulder translate into signals of class, status, and cultural affiliation.

One way to interpret this «internal urbanization» of the home is as a reversal of the conventional relationship between the home and the city. According to the traditional European city concept, the home was the place of retreat and the city served as the public square. Today, however, the distinction between «polis» (city) and «oikos» (household) is becoming less clear. Architecture now involves arranging relationships and experiences that take

place in a hybrid reality that combines the digital and physical worlds, rather than just putting things together in space.

Urban ideas, influenced by Le Corbusier and later by CIAM, regarding the functional distribution of the city appear to be out of date in this regard. A world where all life is centered in one area renders modernist models that sought to divide functions (housing, employment, recreation, and transportation) into discrete urban zones obsolete. Instead, we are confronted with a new scenario that calls for theories of «poly sensoriality» (Zumthor, 2006), «architecture of atmospheres,» and the «lived city» (Jacobs, 1961), where the significance of space is experienced emotionally and dynamically rather than in functional separation.

The way that architecture is controlled also changes as a result of this blending of residential and public uses.

Today, technology and outside attention entering through the screen exercise control instead of urban regulations or city morphology. As a result, the architectural project needs to ask more and more questions like: how can spaces be made that are both private and visible, private and public, and untouchable yet touchable to the human eye?

Designing a home in this new setting entails creating a little city, complete with all the tensions, liberties, and limitations that the big city has traditionally faced.

The Aesthetics of Isolation and Practices of Resistance

People did not passively accept isolation during a period when physical space was limited and freedom of movement was suspended. Rather, they used space and symbolic action to reestablish a sense of unity. A new architectural style developed during the lockdown, when the house was a microcosm of social activities and the city was reduced to a silent landscape. It has to do with communication and experience rather than form.

The balcony—once an extension of the dwelling—transformed into a spontaneous public stage for collective performances: concerts, applause, and messages of hope. The building façade became a canvas for projecting collective identity. These gestures—beyond everyday actions—recall Hannah Arendt’s idea that political action begins when people appear together in public space, making their existence visible (Arendt, 1958). Even when physical space is absent, the desire to appear and coexist does not disappear—it emerges in new, creative, and poetic forms.

Bernard Tschumi once again defined architecture as an act rather than a thing in this context: «There is no architecture without action, no architecture without events, no architecture without program» (Tschumi, 1994).

These acts of seclusion constituted cultural resistance, in which the routine of daily existence interfered with established systems and turned them into means of communication. Instead of altering the constructed form, they altered how people saw space, moving architecture away from aesthetics and toward morality. This change would be interpreted by Henri Lefebvre,

who saw space as a social product, as a type of «urban ritual within intimate space»—a reappropriation of space by its users (Lefebvre, 1991). In addition to serving a practical purpose, the room, balcony, and window were utilized to convey and express connection, identity, and memory.

Alejandro Aravena's theory that architecture is a collaborative process that responds to social reality is also consistent with these commonplace gestures. We created new forms of spatial solidarity instead of new walls in isolation, which Aravena referred to as «a tool to empower communities through the construction of shared experience» (Aravena, 2016).

Thus, architectural space in isolation was not erased, but rather poetized. It was used to protect intimacy and to communicate publicly—simultaneously. This interweaving of function, symbolism, and sensitivity transformed even the smallest space into a place rich in emotional and political meaning. The lived experience became the message. Architecture, detached from its traditional objectivity, re-emerged as an internal language of resistance and memory.

Toward an Architecture of Interfaces

It is not possible to interpret the experience of isolation and screen-based interaction as a passing anomaly, but rather as a heightened tension between the public and private spheres, the physical and virtual worlds, and the physical presence and digital visibility that are already present in architecture and urbanism. In this way, rather than an architectural crisis, we are seeing a new epistemological enclosure that necessitates rethinking architecture's place in modern society.

The architecture of the future must be envisioned as a system of interfaces, where the material and the immaterial, the fluid and the static, live in a creative tension, if space during the pandemic turned into an interface—for appearance, communication, control, and hope. This necessitates changing the emphasis from construction to interaction, from the item to the experience. Architects are now curators of life situations and designers of connections that take place in both real-time and extended-time places, rather than just designers of forms.

This change is essential. Rethinking architecture as a process rather than just a final result is necessary. According to Bernard Tschumi (1994), architecture is more than just a structure; it is an activity, an event, and a momentary meaning that takes place in a particular location.

We also adhere to Henri Lefebvre's (1991) reasoning, which holds that space is never neutral but rather an ordered structure of social relations—a method of understanding and building society.

In a time where physical boundaries are frequently brittle or imperceptible, modern architects must consider new issues: How can we design environments that maintain sensitivity and a sense of belonging? Can the body be visually projected rather than physically present in a «place» that we design? In architecture, how should time be experienced when life cycles are broken, accelerated, or fragmented?

These are not merely artistic or technical problems; they are also ethical and geographical politics, probing how we construct a sense of «somewhere.»

Accordingly, interface design is not the demise of form but rather the start of a new strategy in which mobility, fragmentation, and temporariness serve as new building blocks.

The way architecture faces time, gives form to extended temporariness, and constructs in reaction to changes, crises, and interruptions is examined in Chapter Two, «Permanent Temporalities,» which begins with this conclusion. If space was discussed in this chapter as a location of brittle experiences and mediated connections, then time as architectural matter—a type of stability and transition—will be covered in the following chapter.

virtually present, physically invisible

first volume
Tirana Architecture Triennale Vol. I

The first volume of Tirana Architecture Triennale, under the statement “Virtually Present, Physically Invisible” references its title from the mixed reality installation by Mexican director Alejandro G. Iñárritu, *Carne y Arena*, (Virtually Present, Physically Invisible) (2017). Rather than defining its topic similarly to Iñárritu’s installation, the Triennale perceives “Virtually Present, Physically Invisible” as keywords for a non-absolute definition, but a state of human transition from the Holocene to the Anthropocene.

The concept of always being reachable makes us present nowhere. (Peter Arvai, 2022). Such a statement follows a constant necessity to always engage, but almost never act. This new transitional state, provides coordinates for our geographic state, but not status and operation. Our narratives have already progressed from physical dialectics, towards a duality of waves and particles in the composition of matter, but what is beyond? Global changes, natural and artificial emergencies have forced us to adapt into a new way of living, working and thinking. In this new paradigm shift, which is the role of the architect?

How is architecture actually created? What is it, as architects, that we actually produce? In this new social state, between material and immaterial, digital and analogue, virtual and physical, how can we contribute in our role as thinkers, makers and mediators?

In this entropic state of transitions are we articulating dialectic statements to prevent an apocalypse? or we must prepare a society for a post-apocalyptic scenario? (A. Bolanos, P. Goldin, 2022).

In this frame of operation, Tirana Architecture Triennale, will investigate a new “sense of place” experimenting with conventional yet not fully defined mediums, such as art and technology, faith and religion, the sense of living and co-existing in community. As contextual happenings in architecture and urban development in Albania, the Balkan Region and internationally, a new global gravitation is present, without yet clear orbits.

The discipline of architecture, even if it aims to construct physical artifacts in specific geographic locations, at first is expressed through digital tools and mediums. As its anticipated results aim to be material, they are almost always produced through immaterial processes. In this sense the discipline itself drives the architect to be virtually present, while physically invisible in the product of his work.

TIRANA ARCHITECTURE
TRIENNALE

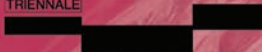

UNIVERSITETI
BARLETI



Co-funded by
the European Union

LIINA

“Virtually Present, Physically Invisible” will aim to dialogue between variants, rather than results.

20
CONTRADICTORY
ITEMS



ZOOM

OPEN LECTURE
Sir Peter COOK



VIRTUALLY
PRESENT
PHYSICALLY
INVISIBLE



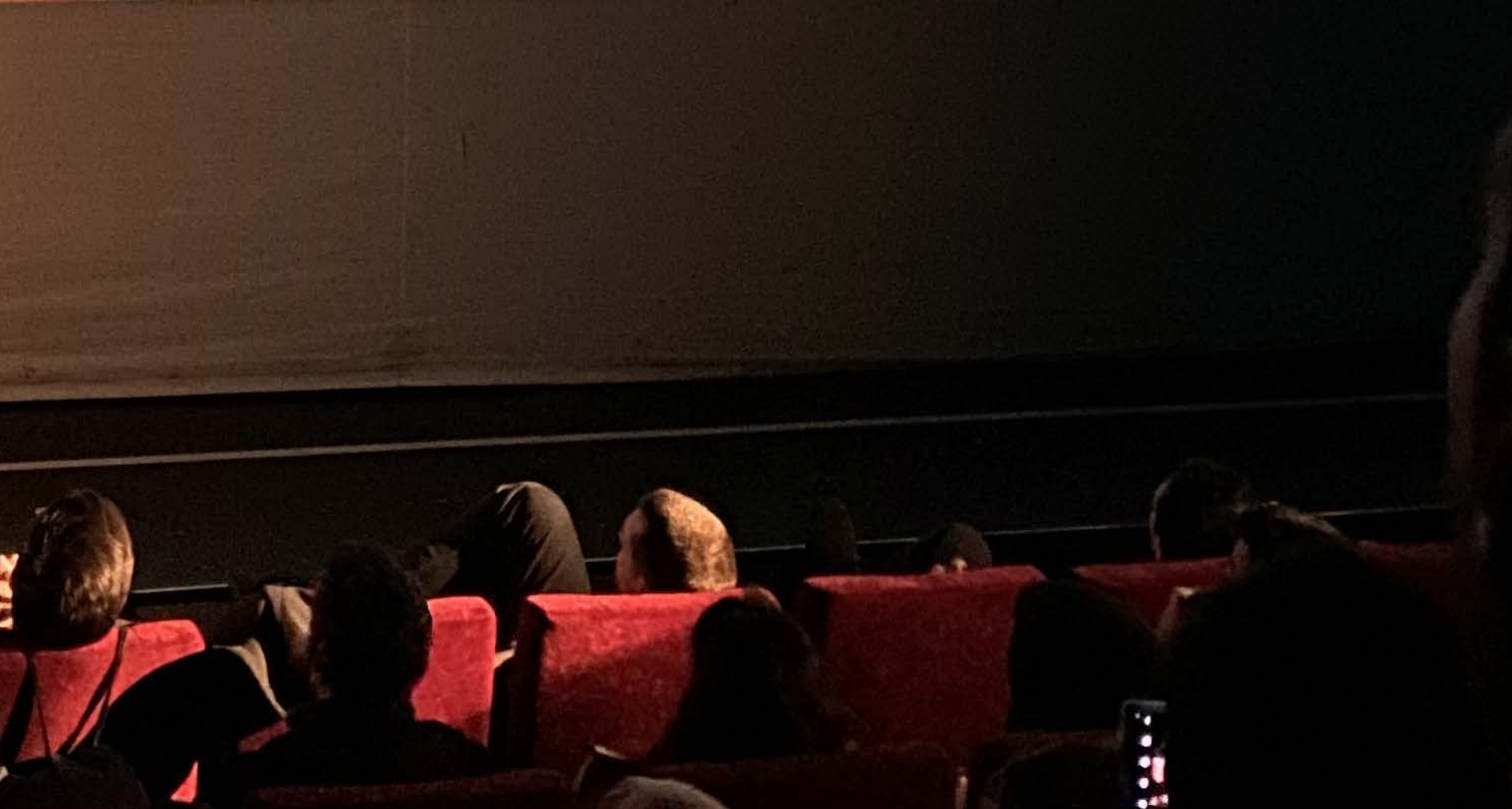

schoolstreet(s)

public performance

Filter Café Filtré Atelier

local collaborator: Qendra Marrëdhënje

The streets around a «Emin Duraku» school in Tirana came to life through SCHOOLSTREET(S) TIRANA, a one-day urban activation event that transformed a typical school street into a vibrant, safe, and inclusive public space for children, teachers, parents, and neighbors. Inspired by similar initiatives in Belgium and other European cities, the event blended urban play, community expression, sustainability, and art.

The pavement was turned into a collaborative canvas where children, volunteers, and artists created visual interventions using chalk-based paint and stencils. White dots, playful circles, colorful lines, and abstract patterns adorned the road, offering both symbolic and interactive elements. Bollards and poles were also decorated, giving the area a festive and welcoming look.



A lively dance performance energized the street, inspired by the protest choreography of *Ultima Vez* / Wim Vandekeybus. Local performers and children engaged in collective movement, activating public space as a stage for joy and expression. “Birds” — a poetic gesture inspired by European open street performances — also made an appearance, blending dance with narrative play.



Teachers and students collaborated to prepare food and host a street picnic, inviting community members to share a meal in the open air. Food became a unifier — turning the event into a celebration of hospitality and togetherness.

Simple but impactful micro-interventions were made to green the street, with added plants and natural elements to soften the urban landscape. Children helped install playful features, contributing to the co-creation of a child-friendly environment.

Throughout the day, the street echoed with music and artistic performances by invited local artists, building a dynamic cultural atmosphere that highlighted the value of reclaiming public space for people, not cars. SCHOOLSTREET TIRANA was more than a one-day event—it was a demonstration of what's possible when a city prioritizes inclusivity, creativity, and community in urban design. It offered a glimpse into a more sustainable and joyful city, one where children lead the way in reimagining our streets.

rrrubble

workshop
Space Saloon & The MAAK
local Collaborator: Saimir Shtylla

In recent years, Tirana has undergone intense urban development fueled by internal migration and speculative construction. Amid this transformation, traditional domestic objects and furnishings have been cast aside—symbols of a past that no longer aligns with the aesthetic aspirations of contemporary living.

The RRRUBBLE workshop aimed to challenge this rupture by applying its methodology to reclaim and reinterpret abandoned furniture. The focus was not only on material reuse but also on restoring cultural and emotional value through participatory research and digital experimentation.

Participants—students from the Faculty of Applied Sciences and Creative Industries at BARLETI University—engaged in a learn-by-doing process structured around four phases:

Participants scouted and selected discarded household objects from around the city. Through interviews and documentation, they uncovered stories of ownership and use, creating a rich archive of personal, social, and material histories.

Each object was physically deconstructed to reveal its structure, wear, and composition. Students were introduced to circular design principles, learning how to identify potentials for reuse and reinterpretation.

Through 3D scanning, modeling, video editing, sound sampling, and live video mapping, the disassembled objects were digitally reconfigured, producing speculative prototypes and layered visual narratives.





An abandoned shopfront in central Tirana was transformed into a critical display space. The intervention combined physical elements of the reassembled objects with real-time digital projections, turning the window into a metaphorical and literal two-way mirror—simultaneously looking back at forgotten pasts and forward toward alternative, post-consumerist futures.

A site-specific multimedia installation that merged analog materials with digital storytelling.

The creation of an open-source digital archive cataloguing the selected objects along with their physical data, narrative context, and visual reinterpretations.

A comprehensive exploration of urban material culture in Tirana, revealing the dominance of generic, globally produced items and highlighting gaps in local design memory.

Enhanced student competencies in multimedia design, object analysis, collaborative making, and critical thinking around resource use and cultural identity.

While the workshop revealed a surprisingly generic palette of discarded objects—indicating a broader trend toward international homogeneity in material culture—it succeeded in demonstrating the potential of everyday things to carry complex meanings. The high level of digital engagement among participants affirmed their adaptability and interest in experimental design approaches. Future iterations of the workshop could benefit from a stronger focus on narrative-building and deeper engagement with local craft and repair practices.

RRRUBBLE x Tirana stood as a reflective and tactile response to the Triennale's central theme, Virtually Present, Physically Invisible, offering an urban archaeology of Tirana's shifting material and cultural landscape.

sacred grounds

exhibition

A Spatial Conversation on Sacred Architecture

New South - Meriem Chabani and John Edom

local collaborator: Iris Nela, Koi Barbullushi

Conceptual Framework

“Sacred Grounds” is not simply an installation but a spatial manifesto—an exploration into the multiplicity of sacred architecture and its reinterpretation in a contemporary and secular urban context. The project is constructed around the symbolic thresholds, forms, and rituals that define six major religious traditions: Islam, Bektashism, Orthodox Christianity, Catholicism, and Judaism, with a unifying frame for all religions.

Rather than isolating these belief systems, the installation juxtaposes their architectural markers, creating a shared and reflective zone that invites both interfaith dialogue and critical meditation on the built environment of belief.

- All religions: the door, the transition between profane and sacred space
- Islam: the floor, demarcated as sacred and oriented toward Mecca
- Bektashi: spolia, the alteration and reuse of sacred architecture to meet the current needs of believers
- Orthodox: horos or polyeleos, representing the Saints
- Catholicism: an enclosure lined by the stations of the cross, oriented to the East
- Judaism: the ark, container of the sacred texts

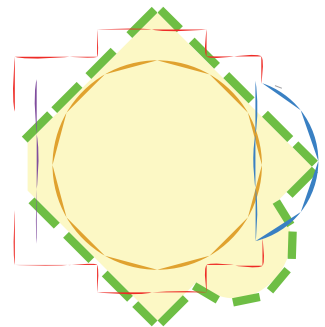

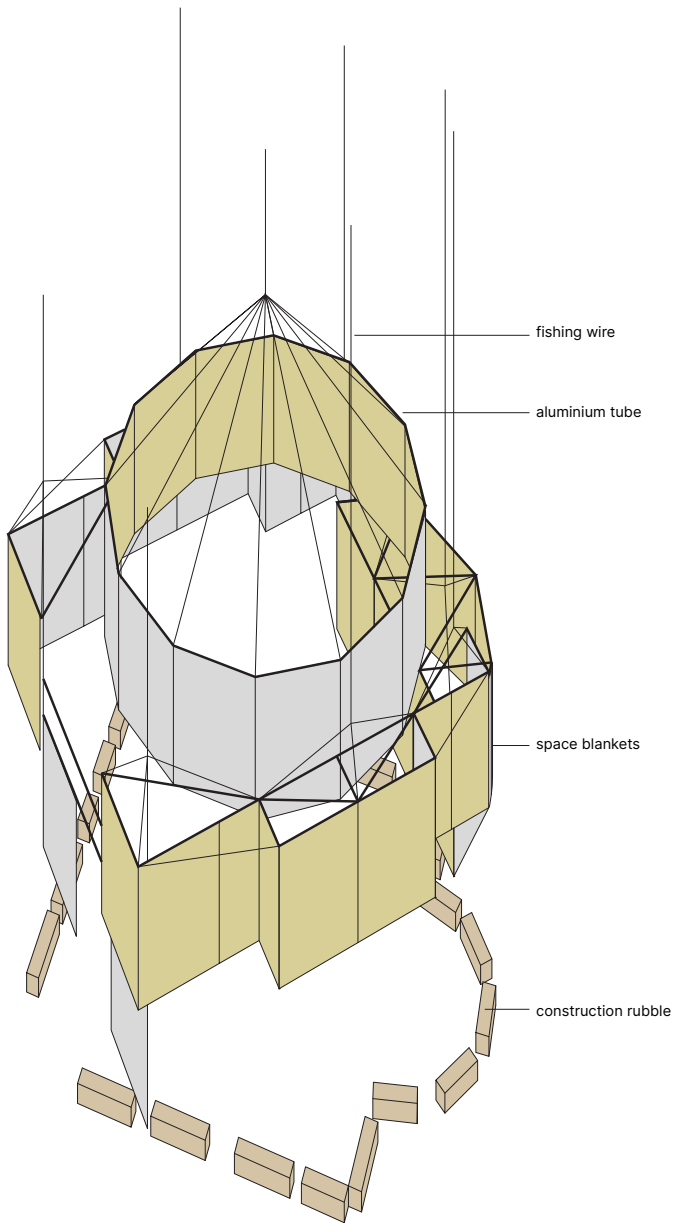

axonometrie

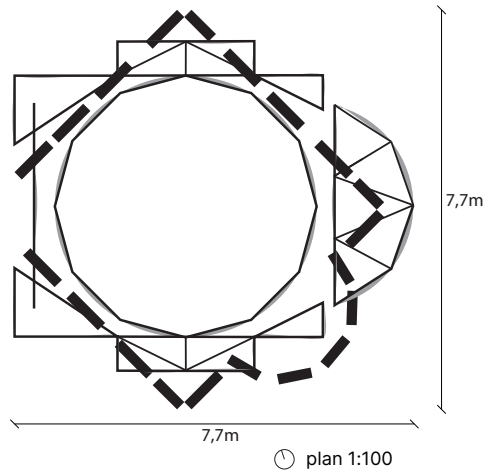
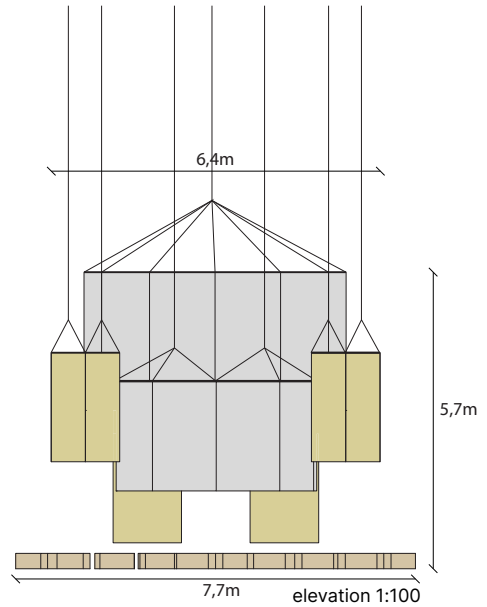

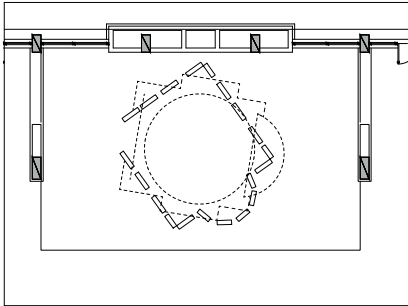

🕒 plan 1:200

Architectural Elements and Religious References

Each segment of the installation corresponds to a particular symbolic or spatial element associated with a specific religion:

All Religions: A door, representing transition between the profane and the sacred

Islam: A floor zone oriented toward Mecca, defining the directionality and sanctity of space.

Bektashi: Use of spolia, referring to reused sacred architectural fragments—evoking memory, transformation, and reinterpretation.

Orthodox Christianity: A reference to the horos or polyeleos, which are suspended ornamental elements representing the divine presence of saints.

Catholicism: A linear enclosure marked by the Stations of the Cross, oriented eastward.

Judaism: The Ark—the container of sacred texts—signifying reverence and preservation.

These architectural references are assembled in a way that preserves ambiguity—allowing visitors to move through and interpret the space without hierarchical cues.

Material Language and Spatial Assembly

The installation was deliberately built with a lightweight, ephemeral material palette: Aluminum tubes (6–8mm), totaling 83 meters, served as the structural skeleton. Space (survival) blankets created reflective, quasi-sacred planes that captured and distorted light—suggesting transcendence and impermanence. Fishing wire (400m, 20kg tension) provided the invisible suspension system, reinforcing a sense of levitation and fragility.

Construction rubble from demolition sites introduced sacred decay and urban memory, anchoring the installation to its physical and historical context. The entire structure weighed only 7.8 kg, yet it spatially invoked the gravity of sacred architecture—a striking contrast between material lightness and conceptual depth.



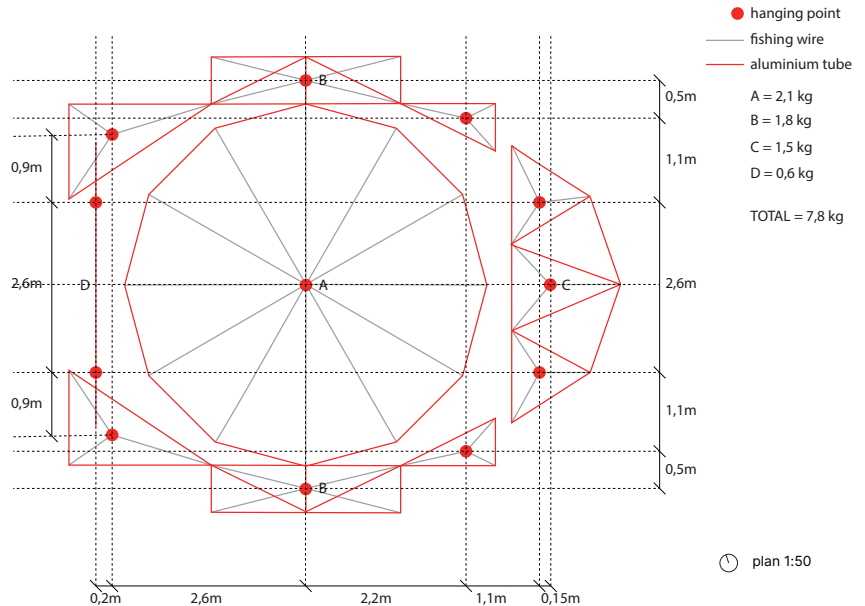

Spatial Impact and Experience

The visitor's experience is shaped through, suspended boundaries and reflective materials that distort spatial perception, narrative layering of architectural and religious memory an invitation to pause, observe, and engage in introspective thought. Rather than reproducing specific religious sites, the installation abstracts their essence, thereby creating a new terrain—a shared sacred ground that exists between traditions.

New South

New South is an architecture studio working between Europe and North Africa, with a focus on social equity, spatial justice, and transcultural urban narratives. Meriem Chabani brings perspectives from Algeria and France, informed by interdisciplinary thinking and postcolonial theory. John Edom is trained in the United Kingdom, working at the intersection of architecture and socio-political research. Together, their practice challenges dominant spatial paradigms by engaging with marginalized narratives, contested spaces, and the rituals of everyday life.







roundtable: «virtual and/or physical?»

panel discussion

participants: Hubert Trammer, Miguel Santos, Anna Sala,
Thomas Dumke, Etleva Dobjani, Tinatin Gurgenidze-Schmitt,
Dijana Vucinic, Saimir Kristo, Christoph Thun-Hohenstein,
Anastasia Zhuravel

Conceptual Framework

The roundtable discussion «Virtual and/or Physical?» took place at COD - Center for Openess and Dialogue as part of the inaugural edition of the Tirana Architecture Triennale, under the framework of the NEW TEMPORALITY Platform. This event explored the evolving dynamics between virtual and physical spaces, focusing on how digital platforms have reshaped our interaction, presence, and expression. With physical presence becoming less central and virtual mediums gaining prominence, the roundtable sought to examine how architects, academics, organizations, and individuals can adapt to these changes without losing the essence and depth of ideas, engagement, and purpose.

Enhancing Physicality, Institutionalizing Virtuality: The discussion focused on the challenges and opportunities of incorporating virtual elements into physical practices, particularly within institutional settings. It explored how virtual spaces could complement and enhance physical presence, and how institutions could support and sustain this balance.

Virtual Temporalities, Physical Permanencies: The conversation considered the intersection of digital spaces and temporalities with physical permanence in architecture and urban planning. Participants examined how to maintain continuity, depth, and authenticity in digital environments while ensuring that physical places retained their significance and permanence.

Non-Binary Mediums: This topic explored the potential of hybrid spaces that transcend traditional physical and virtual boundaries. The focus was on how non-binary mediums



could bridge gaps, enabling new modes of expression and interaction in a more inclusive and flexible way.

The roundtable served as an important platform for interdisciplinary discussions on how the relationship between virtual and physical spaces was reshaping architecture, culture, and urbanism. Participants engaged in insightful exchanges, pushing the boundaries of traditional concepts and contributing to a more connected and resilient future.



NATURALLY
PRESENT
PHYSIO
UNVI

VIRTUALLY
PRESENT
PHYSICALLY
INVISIBLE

permanent temporality

second volume

Tirana Architecture Triennale Vol. II - Permanent Temporality

Architecture as Construction in Time

Architecture constitutes a deliberate intervention in the temporal dimension: it is not merely the realization of form, materiality, or program at a given instant, but an event that unfolds across past, present, and future. From its inception—driven by an immediate functional requirement—a building continues to engage with collective memory, cultural narratives, and the built environment long after its completion. In this sense, we may conceptualize architecture as a temporal body that both generates and responds to time, shaping human experience by materializing sequences of use, perception, and recollection.

Temporariness and Permanence

Rather than opposing polarities, temporariness and permanence constitute twin modalities through which architecture inscribes meaning into the urban fabric. As Frampton (1983) argues, every structure negotiates a tension between continuity—carrying forward historical narratives—and fragmentation—remaining open to reinterpretation and change. Consequently, no edifice is ever “final”; its semantic register evolves as social values, functions, and modes of occupation transform over time.

Architecture as Palimpsest

This dynamic relationship can be framed within Lefebvre’s (1991) notion of the urban palimpsest: the city as a layered archive of social relations. Zumthor’s description of architecture as “time turned into space” (1998) underscores how material assemblies record cycles of habitation, ritual, and silence. Each intervention—whether monumental or ephemeral—becomes a trace superimposed upon antecedent layers, producing a multi-valent text that residents continually read and rewrite.

Linguistic and Mnemonic Dimensions

Moneo (1992) extends this analogy by defining architecture as a language inscribed in the city's body. Buildings enter into dialogic exchange with their surroundings, not by mimetic replication but through a process of ongoing rearticulation. Similarly, Arendt's (1958) concept of the "common world" positions architecture as material testimony to human action—structures that endure as vehicles of collective memory and public history.

Philosophical Foundations of Temporal Experience

The phenomenology of lived time—Bergson's *durée* (1911)—invites us to regard buildings as processes rather than fixed artefacts. *Durée* emphasizes the qualitative flow of consciousness, suggesting that a structure's significance accrues in the overlap of past impressions and future anticipations. In parallel, Bakhtin's (1981) chronotope reveals how spatial forms inherently script modes of social time: ritual procession, daily circulation, or domestic repose all inscribe unique temporalities within architectural configurations.

Archives, Dissemination, and Decolonial Perspectives

Architecture also functions as an archival medium (Derrida, 1995), preserving events and enabling their continual reinterpretation. Every design gesture can be viewed as an archival intervention that both secures and unsettles memory. Contemporary debates in decolonial theory (Maldonado-Torres, 2008) compel to recognize plural temporalities, site-specific memoryscapes that honor vernacular practices, seasonal cycles, and marginalized histories alongside official narratives. Integrating oral traditions and ancestral knowledge, architects foster epistemic justice, ensuring that spaces serve as inclusive repositories of shared heritage.

Sustained Transformation and Ethical Imperatives

Finally, understanding architecture as sustained transformation carries ethical implications. If buildings are inherently fleeting, designers bear responsibility not only for their creation but also for their planned deconstruction, reuse, or memorialization. This “temporal contract” prescribes a lifecycle approach—minimizing waste, preserving material value, and offering frameworks for future reinterpretations.

In sum, a scientific framework for architectural temporality requires:

- Conceptual clarity, distinguishing between markers of continuity and moments of rupture.
- Methodological tools, such as rhythm analysis (Lefebvre) and time-geographies (Hägerstrand), to map overlapping social cadences.
- Ethical protocols, embedding lifecycle planning into design briefs.
- Decolonial sensibilities, foregrounding diverse narratives within the urban archive.

Viewed through this integrated lens, architecture emerges as a living archive of human rhythms—a discipline poised at the intersection of history, phenomenology, and social justice, continually co-authoring the temporal arc of the places we inhabit.

The City as a Living Palimpsest

At the urban scale, the city functions as a living archive of permanent temporariness: a continuous body evolving through fragmented, non-linear layers that defy systematic order. This stratification generates a palimpsest—successive urban interventions that preserve traces of the past beneath new coatings, yet remain legible and re-legible to those who navigate and inhabit the space. As Lynch (1960) argues, the city is a “perceptual map” in which each layer constitutes a potential reading or re-reading, with no possibility of complete erasure.

Projected Territory and Incompleteness

Corboz's (1983) concept of the *territoire projeté* underscores the city's inherent incompleteness: though it may appear fixed at any moment, it remains open to continual redefinition. This ongoing projectuality is particularly evident in post-socialist contexts, where interventions from disparate epochs coexist in a temporal hybridity. In such settings, rapid transformations—often abrupt or externally imposed—intertwine with surviving historical fabric to produce an urban identity that is simultaneously fragmented and coherent.

Constructed Otherness and Multilayered Identity

Massey (2005) frames every city as a “constructed otherness,” where geography and history co-experience to forge a multilayered identity. Here, abandoned or repurposed buildings become material embodiments of temporariness, while new constructions stand in stark relief against older structures, forging a hybrid continuum rather than a clean break between past and present. In this archive, architecture is not merely physical space but an evolving textual field that carries memory, meaning, and a commitment to continuity—an understanding reinforced by Moneo's (1992) view of architecture as symbolic articulation of cultural identity.

Spatial Practices and Everyday Rhythms

Beyond built form, everyday practices inscribe temporal layers into the urban fabric. De Certeau's (1984) notion of the practice of everyday life demonstrates how walking, detouring, and informal uses constitute a living script of urban time, legible in patterns of movement, graffiti, and spontaneous gatherings. Similarly, Hägerstrand's (1970) time-geography maps individual and collective trajectories within space-time prisms, revealing “temporal densities” across districts—rush-hour flows, seasonal festivals, nocturnal economies—that planners can respect or amplify through flexible thresholds and interim activations.

Thirdspace and Threshold Moments

Soja's (1996) Thirdspace theory celebrates the hybrid interplay of the physical (Firstspace) and the conceptual (Secondspace), proposing that the city's dynamism arises where memory, materiality, and imagination converge. Under this framework, architects and planners can design threshold interventions—temporary installations, performative events, augmented-reality overlays—that make latent potentials visible and catalyze collective reinterpretations of place.

Temporal Stewardship and Collective Memory

Rossi (1966) emphasizes collective memory as a guiding principle: every street segment and building carries mnemonic value beyond individual lifespans. Urban interventions thus become acts of temporal stewardship, curating an ongoing dialogue with the city's archive rather than seeking closure. Foucault (1986) further reminds us that urban space is a site of power and representation, where built interventions generate meaning and shape collective identities through their temporal inscriptions.

The Human and Architecture: Experiencing Time Through Space Architecture as Temporal Infrastructure

For the human body, architecture is never a neutral backdrop but a dynamic medium that both registers and generates time (Merleau-Ponty, 1945). Morning light animates thresholds; floor textures cool beneath bare feet at dusk; echoes accumulate in stairwells—all phenomena that inscribe the passage of hours, seasons, and years into our embodied experience. In this sense, buildings function as temporal infrastructures that channel both private and collective rhythms—dinnertime rituals, ceremonial processions, daily commutes—transforming walls and corridors into repositories of shared temporality (Bachelard, 1958; Lefebvre, 1991).

Phenomenology and Poetic Memory

Gaston Bachelard's concept of the house as an "organ of poetic memory" highlights architecture's capacity to encapsulate fragments of personal and communal life (Bachelard, 1958). Every nook or aperture can crystallize memories, yet this process extends beyond individual recollection: it is intersubjective, weaving personal impressions into a collective tapestry. A phenomenological approach urges architects to foreground sensory engagement—recognizing materials as time-generative media whose patinas, thermal qualities, and acoustic properties evolve through habitation (Frampton, 1983). By attending to these material dynamics, designers cultivate atmospheres that resonate with lived temporality rather than flattening experience into uniform utility.

Rhythmanalysis and Temporal Scenarios

Henri Lefebvre's rhythmanalysis offers methodological tools for mapping overlapping cadences of work, rest, celebration, and memory across a single site (Lefebvre, 1991). Rather than fixing architecture as a static form, one can devise temporal scenarios—layered sequences of interventions that invite inhabitants to co-author spaces over time. Scripted as episodes of openings, closures, and adaptations, these scenarios honor the multiplicity of human rhythms and foster environments that adapt organically to shifting social needs.

Architects as Choreographers of Temporal Experience

Reconceiving the architect's role as a choreographer of experience reframes design as an act of time-making. It prompts questions of anticipatory tuning: How might form and material anticipate bodily enactments of time? How can architecture remain porous to unpredictable life flows while offering frameworks of comfort and belonging? Addressing these questions requires embedding temporal contracts—explicit frameworks for use-

value, deconstruction, and material reuse—into the design brief, ensuring that every building carries both functional and ethical lifecycles (Derrida, 1995).

Architecture in Crisis Contexts

In an age of ecological, political, and economic crises, architectural temporality manifests in accelerated cycles of creation, decay, and reinvention. Buildings subject to rapid deterioration, emergency shelters erected for immediate needs, and structures rendered obsolete by functional redefinition all attest to architecture's inevitable entanglement with decay. Faced with its own transience—relocation, dismantling, or collapse—architecture must reconceive deterioration as intrinsic to its life cycle and evolution rather than an aberration.

Globalization and Homogenization

Beyond natural degradation, globalization imposes additional temporal pressures on the built environment. The rapid diffusion of typologies and aesthetics fosters architectural homogenization, detaching forms from local specificity (Massey, 2005). Oversized, standardized structures—often insensitive to scale, climate, and cultural context—erode the connection between built form and human experience, threatening the production of place-based meaning.

Junkspace and the Loss of Memory

Koolhaas's concept of "Junkspace" (2001) diagnoses contemporary architecture as a realm of disposability—spaces conceived for fleeting consumption that sever ties with history and landscape. These ephemeral constructions fail to generate collective memory, undermining architecture's capacity to establish sustainable bonds with land, identity, and community.

Critical Regionalism as Counterpoint

In response, critical regionalism (Frampton, 1983) advocates an architecture rooted in local traditions and environmental conditions, not as nostalgic revival but as a processual dialogue with time and place. By privileging contextually informed strategies—material selection, vernacular construction techniques, climatic adaptation—this approach transforms fragmentation into opportunity for memory-rich interventions.

Ethical Temporality and Temporal Contracts

The recurring cycle of build-and-demolish raises urgent ethical questions about our duty to future generations. Ethical temporality demands that designers embed “temporal contracts” into every project—frameworks specifying anticipated lifespan, ecological impacts, and end-of-life strategies for materials and social fabrics (Derrida, 1995). Such foresight mitigates waste, preserves embodied energy, and honors architecture’s legacy beyond its functional phase.

Hauntology and Active Palimpsests

Derrida’s hauntology (1994) reveals how the past “haunts” present sites, suggesting strategies that expose archaeological layers, surface patinas, or structural scars. By treating buildings as active palimpsests, designers foster temporal reciprocity in which past, present, and future cohabit—challenging demolition as the sole route to renewal.

Non-Places and Temporal Placemaking

Augé’s “non-places” (1995)—airports, malls, data centers—embody suspended temporality devoid of memory or identity. Temporal placemaking counters this void through locally driven interventions: seasonal events, pop-up markets, or community workshops that reinfuse generic spaces with situated rhythms and collective narratives.

Rhythmanalysis as Design Tool

Lefebvre's rhythmanalysis (1991) maps overlapping temporal rhythms—work cycles, festivals, tourism flows—that characterize urban life. Architecture attuned to these cadences can act as a temporal mediator, adapting programming and form—for example, transforming a market hall into a performance venue or enabling a civic square to flood temporarily for ritual use.

Toward Time-Based Representation and Pedagogy

Traditional orthographic drawings and static models fall short in conveying architectural flux. Time-based modeling—animations, scenario mapping, participatory storytelling—enables the visualization of multiple futures for a single site. In academia, studios might require students to script the “decline, metamorphosis, and revival” of designs, integrating social, economic, and ecological dimensions at each stage.

From Objects to Events

Reorienting architecture from an object-centered to an event-centered discipline unlocks its full generative potential. By embracing temporality as both imperative and resource, architecture can address crisis, uphold cultural continuity, and co-author evolving narratives with communities. In this way, the discipline transcends mere resistance to change and participates actively in the unfolding story of our shared world.

Temporality as Method and Value

Temporality in architecture should not be construed as a shortcoming but embraced as a deliberate strategy that generates novel opportunities for spatial innovation and aligns built form with society's evolving requirements. In an era defined by rapid change, buildings must accommodate adaptability, relocation, and even planned obsolescence to remain relevant without imposing undue burdens on future generations.

Flexibility as Constructive Strategy

Contemporary architectural practice increasingly demands structures capable of transformation. Flexibility—understood as the capacity for change in form, program, and site—enables buildings to respond dynamically to shifting social, cultural, and environmental conditions. By embedding adaptability into the design intent, architects can prefigure multiple life-cycles for each project, ensuring that interventions remain meaningful across variable contexts (Frampton, 1983).

Ephemeral Installations and Enduring Impact

Temporary pavilions such as the Serpentine installations in London exemplify this approach. Erected for limited durations, these structures provide laboratories for material experimentation, programmatic testing, and public engagement. Their modular, recyclable components demonstrate how transience can catalyze innovation and discourse without committing to permanent construction, which often entails higher cost and greater ecological impact.

Tirana as Experimental Ground

Cities undergoing continuous transformation—like Tirana—offer rich laboratories for temporally resilient architecture. Here, rapid urbanization and cyclical redevelopment intertwine history and modernity, demanding interventions that can evolve in tandem with civic identity. Flexible structures, whether modular housing or pop-up cultural venues, allow the urban fabric to absorb changing needs while preserving its layered narratives.

Temporality as Theoretical Lens

Beyond pragmatism, temporality can be framed as a core tectonic of architectural theory:

- **Events over Objects:** Buildings are conceived as events—sequences of material assembly, occupation, adaptation, and deconstruction—rather than static objects (Zumthor, 1998).
- **Reversibility & Modularity:** Design strategies that favor reversible connections and modular components embed lifecycle thinking into construction, facilitating future reconfiguration and material reclamation.
- **Palimpsestic Layering:** Successive adaptations—seasonal installations, maintenance cycles, program shifts—accrete meaning over time, transforming structures into living palimpsests whose traces enrich future possibilities.

Sustainability and Cultural Mindset

Temporality realigns sustainability from a purely technical imperative to a cultural ethos. By planning for deconstruction and reuse at the project's inception, architects minimize embodied energy and waste. Equally important, they cultivate a mindset of attentive impermanence that invites communities to co-create, adapt, and participate in the ongoing life of places—democratizing design and reinforcing social ownership.

Rhythm of Everyday Life

Attuning architecture to lived time involves acknowledging the rhythms of daily and seasonal life—market days, festivals, community gatherings—and embedding flexibility into spatial frameworks. Lightweight, reconfigurable infrastructures can accommodate diverse programs without the inertia of permanent edifices, thus enabling quicker responses to emergent social needs.

Time-Based Practices

Theoretical and representational tools must evolve accordingly:
Temporal Modeling: Animations, scenario mapping, and participatory storytelling enable stakeholders to envision multiple futures for a single site.

Design Pedagogy: Studio exercises that script decline, metamorphosis, and revival phases compel students to negotiate social, economic, and ecological dimensions throughout a building's lifecycle.

By reframing temporality as a generative principle rather than a constraint, architects and communities gain the creative agency to navigate uncertainty with resilience and respect for history. Time-based practices position architecture not merely as a response to immediate needs but as an ongoing, shared negotiation of past, present, and future realities.

permanent temporality

second volume

Tirana Architecture Triennale Vol. II - Permanent Temporality

Tirana Architecture Triennale Vol. II - Permanent Temporality is organized by Universiteti BARLETI in collaboration with Architecture Fund in Albania supported by the Ministry of Economy, Culture and Innovation of Albania and LINA.Community Platform! Reflecting on the activities of the first edition “Virtually present, physically invisible” prepare for a week of workshops, lectures, film screenings, debates and public happenings!

Short films: Permanent Temporarily
1st Tirana Creative Triennale / “Permanent Temporality”,
Tirana Architecture Festival by the Museum of Architecture of
Tirana and the Albanian Architecture Fund, interdisciplinary
triennial. Emerging architects enter as mentees and LINA
members as mentors in a mentor/mentee program. A series
of short docu-movies linked with architecture, design,
art, city, technology and innovation. Albanian/English.

BARLETI University during Tirana Architecture Triennale will organize lectures, workshops and public installations with LINA fellows, involving students and professionals, institutions and organizations and local community from 22-26.04.2024.

The participation of two LINA Fellows during Tirana Architecture Triennale Vol.II is composed as a duality within a trilogy exploring the topic “Virtually Present, Physically Invisible”. As the three fellows explore topics linked with **material and imaterial**, within the frame of academia, professionals and community.

TIRANA ARCHITECTURE TRIENNALE

TIRANA ARCHITECTURE
TRIENNALE



UNIVERSITETI
BARLETI



Co-funded by
the European Union

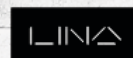

leave no one behind

film and architecture workshop
Exploring Inclusive Design Through Film in Albania's Capital City
Copenhagen Architecture Festival (CAFx) & BARLETI University
local collaborator: Saimir Kristo, Joan Ikonomi

The Film and Architecture Workshop: Leave No One Behind, held in Tirana as a collaboration between Copenhagen Architecture Festival (CAFx) and BARLETI University, brought together students and professionals from diverse disciplines for a powerful week of creative engagement at the intersection of spatial justice, architecture, and film.

Rooted in the core principles of the UN's 2030 Agenda for Sustainable Development, particularly its transformative Leave No One Behind (LNOB) commitment, the workshop addressed pressing questions about how discrimination continues to shape our built environments. Participants explored how architecture can actively respond to inequality—by identifying inclusive spatial solutions and translating them into short, cinematic narratives. Through a week-long intensive program, participants attended lectures by international experts, took part in group exercises, and engaged in site-specific explorations across Tirana. The workshop challenged them to examine which urban spaces allow marginalized communities to feel included, and which inventive architectural strategies help vulnerable individuals navigate and survive exclusion within the city.





With professional support from filmmakers, editors, and architects, each participant developed, filmed, and edited a short film—max. 3 minutes in length—documenting or proposing design solutions that support the LNOB agenda. These films showcased public spaces, buildings, materials, and infrastructures that reflect a commitment to non-discriminatory, inclusive urban environments.

The workshop culminated in a final public screening of all films, at Destil Creative Hub followed by critical discussion and celebration. All entries were officially submitted to the Film Mosaic: Leave No One Behind global short film competition and featured on an open-source platform promoting inclusive design solutions worldwide. Selected films were screened internationally, including at the Copenhagen Architecture Festival x 2023, the UIA2023CPH World Congress, and the Copenhagen World Capital of Architecture 2023.

This unique initiative offered a platform for participants not only to learn about inclusive urban practices, but also to use film as a powerful medium for advocacy and storytelling. It confirmed the vital role of architecture in combating spatial discrimination and the importance of documenting these efforts to inspire global change. The workshop is part of CAFx' contribution to the European architecture platform LINA's Architecture Program and is co-funded by European Union.

between two rivers, one archipelago

summer school
organized by BARLETI University, Tirana in collaboration with
Politecnic University of Bari & Namik Kemal University, Tekirdag

BARLETI University
Prof. Asoc.Saimir Kristo, Prof. Asoc. Etleva Dobjani, Hekuran Bendaj
Politecnic University of Bari
Prof. Asoc. Vincenzo Paolo Bagnato, Prof. Asoc. Antonio Labalestra
Prof. Gian Paolo Consoli
Namik Kemal University, Tekirdag
Prof. Esen Gökçe Özdamar

The Between Two Rivers, One Archipelago international workshop, held in 2025, was a collaborative, multidisciplinary initiative focused on addressing the complex relationship between water, territory, and community in the region surrounding the Vjosa and Seman rivers in Albania. The workshop, organized in the context of the New Temporality platform and facilitated by BARLETI University, brought together experts from various fields—architecture, urban planning, environmental science, and social studies—to explore innovative approaches to territorial development and sustainable coexistence with water resources.

Set against the backdrop of Albania's rich cultural and natural landscapes, the workshop aimed to propose forward-thinking strategies for managing and preserving the unique ecosystems that define the Vjosa and Seman rivers. These two rivers, vital to the local environment and livelihoods, have been under threat from rapid urbanization, industrial development, and environmental degradation. The workshop's primary objective was to design creative, sustainable solutions that balance ecological preservation with economic and social development.



The theme *Between Two Rivers, One Archipelago* reflects the interconnectedness of water bodies, land, and communities, emphasizing the need for integrated, collaborative approaches to urban and environmental planning. Participants were encouraged to look at the rivers not just as isolated entities but as part of a larger territorial ecosystem, encompassing the archipelagos of human, environmental, and architectural interventions.

Participants engaged in a variety of activities, including site visits to key locations along the Vjosa and Seman rivers, collaborative design sessions, and expert lectures on water management, sustainable architecture, and cultural heritage preservation. The workshop provided a platform for participants to exchange ideas, challenge conventional thinking, and collaborate on innovative solutions for water management, flood risk reduction, sustainable tourism, and community-based environmental stewardship. Particular was its emphasis on participatory design, with local communities playing an active role in shaping the

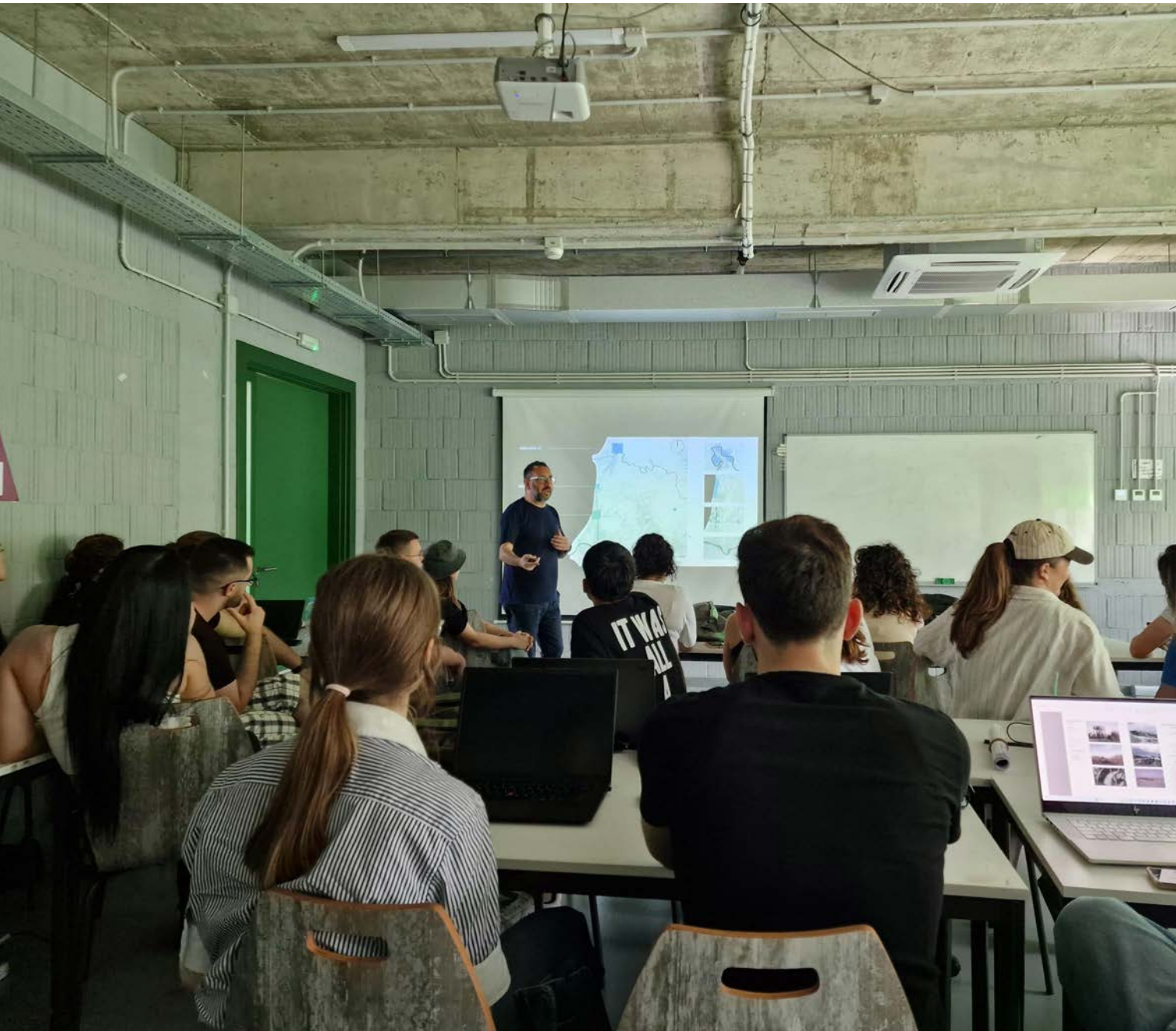

proposed solutions. By involving residents in the design process, the workshop ensured that the solutions proposed were not only environmentally and socially sustainable but also grounded in the local context and knowledge.

The workshop resulted in a series of proposals that integrated sustainable design principles with the region's unique environmental and cultural characteristics. These proposals addressed urgent challenges such as flood management, riverbank stabilization, ecotourism development, and the preservation of natural habitats. Through interdisciplinary collaboration, the workshop generated a set of visionary projects aimed at creating a sustainable balance between human activity and the river ecosystems.

Additionally, the event fostered ongoing collaborations between participating institutions, creating a network of experts dedicated to addressing the complex challenges of territorial development and water resource management in the region. The workshop's outcomes were presented at a public exhibition and discussed in a final roundtable, offering an opportunity for dialogue between academics, practitioners, and local stakeholders.

The *Between Two Rivers, One Archipelago* international workshop was not only an opportunity for collaborative problem-solving but also an important step toward promoting sustainable development in the Vjosa and Seman river regions. The solutions and ideas generated during the event are expected to influence future urban planning projects, environmental policies, and conservation efforts in the area.

Looking ahead, the workshop's interdisciplinary approach and commitment to sustainability will continue to inspire future collaborations and initiatives that prioritize the preservation of natural resources, the empowerment of local communities, and the promotion of sustainable development practices. This event marked a key moment in the ongoing efforts to redefine the relationship between architecture, landscape, and community in the context of environmental challenges which was followed in the thesis level research by students and professors of the respective schools.

yard of fragile onions

urban artistic residency and exhibition

Driant Zeneli

Within the framework of the New Temporality Platform, the installation and exhibition *Oborri i Qepëve të Brishta – The Yard of Fragile Onions* was conceived by visual artist Driant Zeneli and developed collaboratively with a group of students from Barleti University. This immersive and thought-provoking project delves into the deeply ingrained and often invisible social issues within Albanian society, specifically addressing the theme of isolation—both emotional and physical—through the lens of the blood feud tradition in Northern Albania.

The Yard of Fragile Onions explores the emotional and social isolation experienced by children caught in the cycles of blood feuds. This longstanding tradition, grounded in ancient Albanian laws, has severe consequences for individuals and families, particularly children who, due to the violent customs, are often confined to their homes, unable to attend school or socialize freely. This isolation leads not only to a lack of education but also perpetuates the trauma and stigma that these families carry through generations.

The project was informed by detailed research and fieldwork, including a pivotal meeting with Professor Liljana Luani in Shkodër, whose decades-long voluntary work with blood feud-affected communities inspired the installation. Professor Luani's contributions to the community outside of the confines of tradition were pivotal in shaping the work's narrative, which centers on the experiences of children in these communities.



The narrative for the installation draws on real-life stories of blood feuds from the northern regions of Albania, weaving a new fictional tale that both honors and challenges the prevailing customs. The story revolves around two families who lived in a yard surrounded by onions, a metaphorical representation of the isolation they endured. The children from these families grew up together, developing a strong bond and a lifelong love. However, the family's peaceful coexistence shattered when the girl's family decided to emigrate, selling their house and onion garden, which triggered a violent feud between the two families.

At the heart of the installation is the figure of Liljana, symbolized by a Lily flower, who represents the voice of the narrative. Through her eyes, we see the unfolding tragedy, as she watches the relationship between the two families deteriorate. The Lily flower personifies her role as the storyteller, guiding the audience through a journey of transformation and loss. The children are represented by the Laurel (boy) and Violet (girl) flowers, further emphasizing the delicate and fragile nature of their connection amidst the violence that surrounds them.

The installation itself is divided into two rooms, each reflecting the physical and emotional space of the families living in isolation. The objects within these rooms serve as symbolic representations of the lives of those confined by the feud. The students posed the central question: Do objects speak to each other when we are distant, or do they fall silent? These questions guide the exploration of the role of objects in our lives, acting as both functional items and symbolic representations of the emotional and social states of their owners.

The installation invites viewers to reconsider the impact of isolation, both in terms of blood feuds and in a broader context of human experience. By focusing on the symbolism of flowers, the piece offers a fresh and poignant perspective on blood feuds, offering a narrative that goes beyond the violence and trauma often associated with this cultural tradition. This urban artistic residency brought together a talented group of Barleti University students who collaborated closely with Driant



Zeneli. The participating students were: Alesia Fufi, Asterjola Qershori, Bernard Cysa, Ergi Salku, Erinda Çuku, Gesilda Gjergji, Klaudia Bitri, Laurela Mali, Megi Hoxha, Sarah Doka, and Savina Kajo. Together, they engaged in the creation of the installation, blending artistic vision with academic insight to create a powerful statement on isolation, trauma, and transformation.

The Yard of Fragile Onions is an ongoing project, one that will continue to evolve as the students and artist explore new ways to tell the stories of those affected by blood feuds. The installation not only shines a light on an important social issue but also encourages a broader conversation about the role of art in addressing emotional and social isolation. Through this residency, the team has laid the foundation for a more inclusive and compassionate understanding of how art can be used to heal and challenge the silences surrounding difficult histories.

The installation was unveiled during the Tirana Architecture Triennale, with its themes resonating deeply with the overarching concept of «Virtually Present, Physically Invisible,» as it sought to make the invisible emotional and social realities of blood feuds visible through artistic expression.

EMPORARY ARCHITECTURE AND SOCIAL LIVING ENVIRONMENTS ON THE ALBANIAN COAST exhibition

author: Robert Pichler / curator: Saimir Kristo

The Kioska exhibition by Austrian photographer and anthropologist Robert Pichler, curated by Saimir Kristo, made a significant impact as it traveled across Albania. The exhibition was displayed in four key cities—Vlora, Durrës, Fier, and Shkodër—throughout 2025, each stop offering unique opportunities for engagement and reflection on the country's architectural and socio-cultural transformation.

The Kioska exhibition explored Albania's transition in the post-communist era through the lens of informal, makeshift kiosks that dotted the country's coastlines during the 1990s. These simple structures, built without formal architectural planning, became iconic symbols of a time when Albanian society was navigating the challenges of a shifting economic and political landscape. Pichler's photography captures the essence of these transient structures and the everyday lives of those who inhabited them, offering a compelling visual narrative that speaks to resilience and transformation in a time of great uncertainty.



Known for his extensive field research across Southeast Europe, Robert Pichler's work often weaves together documentary and artistic photography. In *Kioska*, he employed his unique approach to photography, focusing on the evolving built environment in Albania as it adapted to the challenges of the 1990s. Pichler's images offered a window into the past, capturing the raw and unrefined nature of these kiosks—structures that were not only physical markers of rapid urbanization but also social spaces for communities in transition. His work resonated with local viewers, many of whom had witnessed these structures come into being during a time of political and economic upheaval.



Curator Saimir Kristo, an architect and academic, brought a deep understanding of Albania's architectural evolution to the Kioska exhibition. Kristo's curatorial approach emphasized the role of informal architecture in shaping the identity of the post-socialist Albanian city. By placing these kiosks within the broader context of Albania's urban transformation, Kristo underscored the cultural and historical significance of these structures, examining how they reflected the social, economic, and political realities of the time. His curation encouraged visitors to think critically about the relationship between architecture, identity, and memory in a rapidly changing society.

The exhibition's reception in each city was powerful, with local residents and visitors alike engaging in thoughtful conversations about the kiosks' role in Albania's history. In Vlora, Durrës, Fier, and Shkodër, the exhibition was carefully adapted to each location's unique context, fostering dynamic discussions around the themes of memory, identity, and the rapid changes that shaped the urban landscape. In Vlora, where the kiosks first emerged as part of the coastal transformation in the early 1990s, the exhibition sparked nostalgic reflections on the city's rapid urbanization. Durrës, with its history of tourism and commerce,

brought out discussions about the commercialization of public space, while in Fier and Shkodër, the exhibition resonated with ongoing urban development projects, as the kiosks reflected Albania's shift from a centralized to a market-driven society.

The Kioska exhibition was a profound exploration of Albania's transition through the eyes of its everyday architecture. With Robert Pichler's poignant photography and Saimir Kristo's insightful curation, the exhibition offered visitors a deeper understanding of the importance of informal architecture in shaping a nation's urban identity. As part of the Tirana Architecture Triennale, it contributed to the ongoing dialogue about the role of architecture in societal transformation, leaving a lasting impression on audiences across Albania, an activity supported by Raiffeissen Invest and the Austrian Embassy in Tirana, Albania. In the aftermath of the exhibition, plans were made for the release of a publication featuring additional academic essays and artistic contributions, scheduled for spring 2025 by Bahoe Verlag. This book will further explore the themes of the exhibition and its relevance to contemporary architectural discourse.







welcome to mediterranean!

exhibition

100 Ideas for Western Balkans Designing Urban Imaginaries

Urbanthinktank_next: Hubert Klumpner and Michael Walczak
Architecture Fund in Albania: Saimir Kristo

Supported by the Austrian Federal Ministry for European and International Affairs, the Austrian Federal Ministry for Arts, Culture, Civil Service and Sport, the Austrian Embassy in Tirana.

«Welcome to MediTirana!» marks the Tirana edition of the exhibition «100 Ideas for Western Balkans – Designing Urban Imaginaries.» Initially introduced as the «Sarajevo Architecture Olympics» during the Days of Architecture, this exhibition has evolved to showcase innovative architecture and urban development projects from the Western Balkans. In its Tirana iteration, the focus shifts to the burgeoning role of Tirana as the seafront of the Western Balkans. As the dynamic capital of Albania, Tirana has transformed into an urban laboratory, propelling itself onto the global stage as an architecture and lifestyle destination. This exhibition unveils the city's unique character and potential, inviting audiences from around the world to witness the exciting evolution of Tirana's urban landscape. «Welcome to MediTirana!» invites attendees to explore the vibrant fusion of contemporary architecture and urban planning that defines Tirana. From informality into innovative cityscapes and later to sustainable development projects, the exhibition showcases the city's metamorphosis into a hub of creativity and progressive urban living. By delving into Tirana's architectural palimpsest, visitors will gain insight into the city's journey towards becoming a cultural and architectural landmark within the Western Balkans. Join us in celebrating Tirana's transformation, recognizing its newfound status as a pivotal architecture and lifestyle destination. «Welcome to MediTirana!» promises a visual and social journey through the architectural stories that define Tirana's role in the heart of the Western Balkans.









Concerning our search for a catalyst of interconnected dynamic processes, methods, and tools, in the Designing Urban Imaginaries exhibition, we present prototypical case studies within four corresponding sub-chapters: NURTURING, DWELLING, MOVING, and GENERATING. Our society needs a holistic vision focusing on many ecological actions to contribute to global transformation. In several subchapters, the invited protagonists show the enormous potential for change in selected areas of our everyday lives: what we eat and how we nurture the environment (NURTURING), how we build and dwell (DWELLING), how we move (MOVING), what we generate and how we can re-generate interrupted material cycles (GENERATING), to mobilize active hope through new perspectives. These are presented on a global, regional, and local scale.

A framework for a new kind of design research agenda of relations, thoughts, concrete materials, devices, and information platforms is proposed. This agenda will augment design as a key to the quality of life. However incomplete and open-ended, it provides a necessary forecast—a collection or toolbox of ideas and concrete pilot projects. It calls upon people from various disciplines to collaborate and brainstorm whether there may be scenarios leading us from the present unsustainable situation towards circular thinking and advocacy for radical care. Design confronts us with possible futures. It presents concrete examples

focused on choices and our influence on and anticipation of a close spiritual connection between a defiant Earth and humankind's power to understand and change the systems of the Earth. Crimson historians and urbanists coined this Anthropocentrism 2.0.

Our call is inseparable from design thinking that connects all disciplines and schools of thought. At the core of this concerted action stands the idea of collaboration instead of competition when it comes to the future of our climate. This places culture, art, architecture, and urban design alongside science, technology, and politics. Fifty years after the publication of the last Whole Earth Catalog, we propose a starting point for developing guidelines that will provide „access to a toolbox for the 21st century.“ This agenda is about concentrating on the Earth as a whole.

This exhibition concept is to build and archive innovative ideas, both practical and metaphorical while starting in Vienna and going to Shenzhen, its goal is to constitute a view of the Western Balkan with a first stop in Sarajevo and now in Tirana. Now, after testing on two continents, ready to build an archive about the tendencies of next-generation architects and urban designers, its goal is to help distribute the shared knowledge gathered around it. This is a transferable concept as many of the design solutions and ideas can also be applied to the Western Balkan and Tirana, where the exhibition is now taking place.



TIRANA ARCHITECTURE
TRIENNALE



UNIVERSITETI
BARLETI



Co-funded by
the European Union

LINA

Jeanne Gang

Open Lecture

Date/Time: 23 April/ 18:00

Location: Arturbina (Teatri Kombëtar)

Jeanne



Jeanne Gang, FAIA, is the founding partner of international architecture and urban design practice Studio Gang. Known for a distinctive approach that expands beyond architecture's conventional boundaries, she creates striking places that connect people with their communities and the natural environment. Her diverse portfolio includes a major addition to the American Museum of Natural History, the re-imagination of the Arkansas Museum of Fine Arts, and the transformation of the Beloit College Powerhouse into a student center. Jeanne is a MacArthur Fellow and has been named one of TIME Magazine's most influential people in the world.

Gang





polymer(ous) therapy

workshop and short film
Magdalena Gorecka, Magdalena Skowrya
local collaborator: Gerdi Papa

Abstract

The Polymer(ous) Therapy workshop, held at Barleti University, addressed a pressing issue in contemporary architecture: the ecological and social potential of incomplete or abandoned structures in urban contexts. The city of Tirana, characterized by its dynamic and often unregulated development, offered a compelling setting for the workshop's central inquiry—how can architectural design, through material experimentation and ecological awareness, serve as a tool to regenerate not only space but biodiversity?

Through mapping, sampling, 3D scanning, and prototyping, students proposed material interventions to “heal” incomplete urban forms using polymers. The intent was both literal and metaphorical: to mend broken architectures while supporting interspecies coexistence in the city. Central to this approach was the notion that materials—especially porous, repurposed, or waste-based polymers—can act as mediators between built environments and natural systems. The workshop provided students with a framework to reflect on architecture's role in shaping more inclusive, biodiverse, and pluriversal urban ecosystems.

The Polymer(ous) Therapy workshop was structured as an intensive, multi-day, practice-based studio involving research, site exploration, and fabrication. The pedagogical model was rooted in project-based learning, interdisciplinary discourse, and ecological sensitivity.

TIRANA ARCHITECTURE
TRIENNALE



UNIVERSITETI
BARLETI



Co-funded by
the European Union

LIINA



Workshop

Date: 22-26 April

Location: Barleti University



Abandoned structures—remnants of unfinished developments, construction debris, or neglected architectural shells—were all inhabited, to varying degrees, by non-human species such as bees, birds, turtles, flies, and insects. Rather than seeing these structures as failures, the workshop reframed them as incomplete ecologies in need of thoughtful repair and design stewardship.

Material-based artefacts were designed to “heal” its chosen site—not through restoration to a former function, but through enhancement of its ecological role and its potential as a shared habitat. The prototypes invited species to inhabit, nest, or adapt to the microenvironments created by polymer structures.

Polymer(ous) Therapy a pedagogical model grounded in experimental learning, ecological literacy, and interdisciplinary collaboration. It successfully shifted the conversation around material use in architecture from efficiency and durability to inclusivity and biodiversity. Through hands-on prototyping, critical discourse, and situated design, students developed a deeper awareness of how materials mediate between urban infrastructure and ecological processes.

Rethinking Material Agency: recognition of materials not as passive tools but active agents capable of shaping spatial experiences and ecological interactions. Polymers, often maligned in environmental discourse, were reconsidered as potentially regenerative when used critically and locally.

Porosity as Design Intelligence: The porous quality of selected polymers proved to be a critical theme. Porosity allowed for water infiltration, plant rooting, species nesting, and light modulation. It also prompted students to consider environmental variables such as heat, airflow, and humidity in their designs.

Beyond the Human: A significant conceptual breakthrough occurred in the realization that architecture should not serve humans alone. Students explored the pluriverse—a reality composed of multiple species, perspectives, and ecological needs. Design became a form of care, not only for buildings but for life in its diverse forms.

Material and Atmosphere: Encouraging a sensory and atmospheric approach to materiality. Students studied transparency, flexibility, degradation, and surface temperature, and how these material traits could foster unexpected aesthetics and responsive environments.

Collaboration and Empowerment: Working in teams fostered leadership, responsibility, and collaborative problem-solving. Each group managed their project development cycle, from research and conceptualization to fabrication and presentation.

Ecological Awareness through Fabrication: Using 3D printing and handcrafting methods allowed students to connect technological processes with environmental ethics. They gained practical skills while debating the ecological impact of digital fabrication, leading to more conscientious design decisions.

Urban Design as Ecological Stewardship: A redefinition of the architect's role—not only as a form-giver but as an ecological steward. By inviting nature into abandoned structures, students proposed new imaginaries for the city of Tirana—ones that value slowness, improvisation, and interdependence.





Future Directions

The prototypes developed in this workshop offer scalable ideas for eco-urban regeneration. Future iterations of Polymer(ous) Therapy could engage with public institutions, integrate citizen participation, and be applied to other cities facing similar challenges of rapid development and ecological loss. A digital platform could document ongoing material tests and ecological outcomes, turning the project into a living archive of design-research. Moreover, the framework could be adapted for different material ecologies—beyond polymers—to include clay, algae, wood waste, or bio-composites, encouraging cross-material dialogue.

Ultimately, this workshop is a small but significant step toward a more inclusive, ecologically responsive, and materially conscious architecture—one that listens to the silent ecologies and urban margins that so often remain invisible.

Foil&Soil, founded by Magdalena Gorecka and Magdalena Skowrya, is a post-plastic lab that challenges the understanding of materials and re-imagines their development and applications on different scales. Foil&Soil serves as a bridge connecting material science, current technologies, and urban planning.

oda mediterrra

intervention and artistic installation

Saimir Kristo, Etleva Dobjani

performance: Argita Prifti

Mies van der Rohe Pavillion, Barcelona

concept: Saimir Kristo, Etleva Dobjani, Ledio Kosta

Abstract

Our contribution part of New Temporality Platform is a reflection on the Mediterranean as a space of encounter, resistance, and unity through a spatial reconstruction of the traditional “oda” and reinterpretation of Mediterranean symbolism through culture, culinary practices, domestic space, design and its imaginary.

The concept behind Oda Mediterra is to celebrate the Mediterranean as a space of collective memory and transformation. Derived from the traditional oda of the Western Balkans and cross-mapped with the Mediterranean concept of the “archipelago,” this installation explores the Mediterranean as an intersection of cultures, ideas, resistance, and hospitality.







Oda është një dhomë e zakonshme në një shtëpi tradicionale shqiptare, e përdorur për mikpritje, shkëmbim kulturor dhe dialog.

An oda is the common room in a traditional Albanian house, used for hospitality, cultural exchange, and dialogue.



The project reinterprets the oda (a key interior space in Albanian homes used for welcoming guests and conducting important discussions) as a metaphorical and spatial vehicle to foster cultural dialogue and promote shared values of hospitality, care, and coexistence. Through a hybrid of domestic settings, soundscapes, and traditional objects, Oda Mediterra invites visitors into a sensorial and symbolic journey.

Oda Mediterra reflects a contemporary longing for rootedness and collective experience. The installation triggers questions around the role of traditional culture in current times and challenges the existing representations of Mediterranean spaces. It becomes a soft platform for discussion, imagination, and performance.

The Mediterranean, with its histories and cultures, is not only geographical but deeply emotional. Oda Mediterra responds to the urgency of redefining Mediterranean values in today's fragmented realities, especially in the face of climate challenges and sociopolitical unrest. It highlights the need to preserve cultural diversity and foster mutual understanding.

In this context, Oda Mediterra acts as a commons of shared experiences, prompting discussions that extend across space, generations, and political borders. It aims to create an emotional and cultural connection through sensory and symbolic experiences, promoting discussions that extend beyond the present moment. The installation emphasizes Mediterranean values of togetherness, care, and coexistence through a spatial composition that bridges past and present, tradition and innovation.



TIRANA ARCHITECTURE
TRIENNALE



UNIVERSITETI
BARLETI



Co-funded by
the European Union

LINA

STEVEN HOLL

Online Lecture

Date/Time: 26 April/ 18:00

Location: Forum Theater
at Barleti University

Steven



Steven Holl was born in 1947 in Bremerton, Washington. He graduated from the University of Washington and pursued architecture studies in Rome in 1970. In 1976, he joined the Architectural Association in London and established STEVEN HOLL ARCHITECTS in New York City.

Considered one of America's most influential architects, he is recognized for his ability to blend space and light with great contextual sensitivity and to utilize the unique qualities of each project to create a concept-driven design. He specializes in seamlessly integrating new projects into contexts with particular cultural and historic importance.

Holl



Jose Luis Chcon to Everyone 7:17 PM
What's the name of the professor who just asked the question?

BinMar Leto to Everyone 7:25 PM
Question to SH: why has Pritzker recognize you as of yet? Is it political?

Who can see your messages? Record

To: Everyone

Type message here...

EM Enola Martopullo

GM ... windows

Mute all

7:28 PM
4/26/20



or
not
ding on
I
/ /
/ /
...
/ /



state of preparedness

short film
Rebeka Bratož Gornik

introduction

This report examines the military heritage of Albania, focusing on the ubiquitous bunkers scattered across the country and the underground city of Kukës, while exploring their historical significance and potential for adaptive reuse. The research draws upon visits to historical sites, firsthand accounts from local informants, and reflections on the personal perspectives of those connected to Albania's military legacy. The central theme explores the relationship between visible and invisible structures, conscious and unconscious fears, and the ongoing impact of this military heritage on Albanian society.

Context of Military Heritage in Albania

Albania's military heritage, particularly the iconic bunkers constructed during the dictatorship of Enver Hoxha, forms the focal point of this investigation. Under Hoxha's regime, a pervasive fear of foreign invasion led to the construction of an extensive network of bunkers and other military infrastructure. It is estimated that over 170,000 bunkers were built during this period, resulting in a unique and widespread architectural legacy that still defines the landscape.

Research involved visiting key locations, including the capital city, Tirana, to understand the context, historical significance, and present-day relevance of these structures in post-dictatorial Albania. This study was enriched by the guidance of Saimir Kristo, an expert informant deeply familiar with the topic, whose insights were instrumental in understanding the modern implications of Albania's military past.



It is a choice to do something different.

The Journey of Exploration

Several significant sites were visited during the research. One highlight was the visit to Bunk'Art, a museum offering a comprehensive view of the terror experienced by the Albanian population under Hoxha's regime. The museum offers a stark portrayal of the pervasive fear of invasion and the harsh living conditions endured during the dictatorship. Together with Saimir's guidance, this experience shaped a deeper understanding of Albania's bunker legacy.

Saimir also introduced me to several initiatives related to bunkers, including the project Bed and Bunker, which he developed in collaboration with his students. This project sought to transform former military bunkers into functional living spaces, highlighting the potential of Albania's military architecture to be reimagined and repurposed to meet contemporary needs through adaptive reuse.

Exploring the Potential for Repurposing

The repurposing of these bunkers has been uneven and gradual. While some have been transformed into bars, storage facilities, or art spaces, many remain abandoned. Their persistent presence across the landscape provokes questions about their relevance and meaning. Some bunkers are hidden beneath the surface, while others remain strikingly visible, particularly in urban areas, acting as ever-present reminders of Albania's militarized past. One notable example is found in Durrës, a coastal city where several bunkers have been converted into bars. These adaptive reuses exemplify Albania's attempt to move beyond its traumatic history while negotiating its material legacy. During fieldwork, I also interviewed a bunker owner along the coast, whose insights revealed a personal and nuanced perspective: ownership of a bunker could symbolize pride, but also carry a heavy emotional and historical burden.



Psychoanalytic Interpretation: State of Preparedness

Reflecting on Albania's military heritage inspired a psychological interpretation framed around the enduring emotional and symbolic significance of these structures. Drawing on Freud's iceberg theory of the unconscious and conscious mind, I developed the concept for a short film titled *State of Preparedness*. Structured as a fictional psychotherapy session, the film imagines a dialogue between a therapist and Enver Hoxha, who is confronted with his fears—fears that mirror the collective anxieties of the Albanian people during his dictatorship.

The film explores how the fear of war and invasion, although unrealized, became embedded in the national psyche. This fear is physically embodied in the bunkers themselves—visible, concrete remnants of invisible psychological trauma. The film's psychoanalytic lens highlights how these structures, once symbols of protection, now evoke past repression and collective unease.



Challenges in Access and Personal Perspectives

A significant challenge throughout this research was accessing personal testimonies from individuals with firsthand experience of Albania's military infrastructure. The sensitive political climate and lingering mistrust made some potential interviewees hesitant to speak. Nonetheless, insights provided by Saimir Kristo and the coastal bunker owner proved invaluable.

The interview with the bunker owner illuminated the emotional complexities associated with possessing one of these structures. More than mere remnants of war, these bunkers can carry profound personal significance—simultaneously physical, symbolic, and psychological. This personal lens brought greater depth to the analysis of how Albania's military heritage continues to be experienced at the micro level.

Short Film Production: Tirana Architecture Triennale

As part of this research, I produced the short film *State of Preparedness*, developed within the framework of the Tirana Architecture Triennale. Despite a tight schedule, the project was successfully executed in one week: Following the screening, a discussion was held addressing the role of bunkers in shaping spatial memory, their cultural significance, and potential for future reinterpretation. This dialogue extended the conversation beyond architecture, into the realms of identity, trauma, and public consciousness.

Post-Research Film Editing

After the initial screening, I revisited the film with a more reflective perspective. The original version, created under time constraints, lacked narrative clarity and psychological depth. Engaging with further feedback and personal analysis, I re-edited the film to strengthen its conceptual framework.

The final version presents a more nuanced and reflective narrative that more effectively captures the complex relationship between Albania's military architecture and its emotional legacy. This revised edit also enabled a deeper exploration of the bunkers' symbolic role—as both tangible artefacts and carriers of collective national memory.



Rebeka Bratož Gornik Rebeka Bratož Gornik Rebeka Bratož Gornik
 Rebeka Bratož Gornik Rebeka Bratož Gornik Rebeka Bratož Gornik
 Rebeka Bratož Gornik Rebeka Bratož Gornik Rebeka Bratož Gornik
 Rebeka Bratož Gornik Rebeka Bratož Gornik Rebeka Bratož Gornik
 Rebeka Bratož Gornik Rebeka Bratož Gornik Rebeka Bratož Gornik
 Rebeka Bratož Gornik Rebeka Bratož Gornik Rebeka Bratož Gornik
 Rebeka Bratož Gornik Rebeka Bratož Gornik Rebeka Bratož Gornik
 Rebeka Bratož Gornik Rebeka Bratož Gornik Rebeka Bratož Gornik
 Rebeka Bratož Gornik Rebeka Bratož Gornik Rebeka Bratož Gornik
 Rebeka Bratož Gornik Rebeka Bratož Gornik Rebeka Bratož Gornik
 Rebeka Bratož Gornik Rebeka Bratož Gornik Rebeka Bratož Gornik
 Rebeka Bratož Gornik Rebeka Bratož Gornik Rebeka Bratož Gornik
 Rebeka Bratož Gornik Rebeka Bratož Gornik Rebeka Bratož Gornik
 Rebeka Bratož Gornik Rebeka Bratož Gornik Rebeka Bratož Gornik
 Rebeka Bratož Gornik Rebeka Bratož Gornik Rebeka Bratož Gornik
 Rebeka Bratož Gornik Rebeka Bratož Gornik Rebeka Bratož Gornik

Conclusion

Albania’s military heritage is represented through its most emblematic structure—the bunker. Concrete remnants are not only physically present across the landscape, etched into the psychological fabric of the nation. They embody a paradox of protection and fear, pride and trauma, permanence and obsolescence. The potential for adaptive reuse—though still emergent—invites a broader rethinking of how Albania can engage with its past.

Meanwhile, the psychoanalytic reading of the bunkers in State of Preparedness opens a window into how fear was institutionalized during the dictatorship and how it continues to reverberate in the collective unconscious of the Albanian people.

By examining the interplay between visible and invisible infrastructures, and the conscious and unconscious narratives that surround them, this research sheds light on how architecture, memory, and trauma intersect. It advocates for a critical, imaginative, and empathetic approach to Albania’s military heritage—one that honors the past while imagining new futures.



You built invincible structures

UALLY
ESENT!
YSICALLY
UBLE

MARKET
PRESENT
PHYSICIAN
INVISIBLE

The Human and Architecture: Experiencing Time through Space
Architecture transcends mere form and function; it is an embodied negotiation of space and time. We do not experience buildings abstractly but through our bodies—sensing the cadence of day and night, the warmth or coolness of materials, the resonance of sound through walls, and the dance of light across surfaces. In this way, architecture becomes the medium through which we measure and understand time.

Gaston Bachelard's *La Poétique de l'Espace* (1957) portrays the house as a vessel of poetic memory: every corner, stair, and attic preserves intimate experiences, allowing the body's recollections to settle like patina on walls. Juhani Pallasmaa, in *The Eyes of the Skin* (1996), critiques modern architecture's overemphasis on vision and reclaims a multi-sensory engagement—touch, hearing, smell—as essential to inhabiting space. Peter Zumthor's *Thinking Architecture* (1998) echoes this, insisting that architecture must be “tangible” and sensibly present to foster meaningful dwelling.

Yet contemporary practice often risks losing this intimate connection: cold functionalism, standardized aesthetics, oversized proportions, and insensitive material choices can estrange people from the lived rhythms of a place. In response, studios such as Caruso St John, Flores & Prats, and Lacaton & Vassal champion an approach that prioritizes conditions for experience over imposition of form. By preserving material histories and respecting traces, they allow time to unfold within structures—turning architecture into an archive of collective memory rather than a blank canvas.

Sala Beckett in Barcelona by Flores & Prats exemplifies this ethos. By retaining the theater hall's shell and integrating new functions, the project becomes a living palimpsest: it archives layers of performance and community life while accommodating contemporary uses.

Every day spent in a space transforms both the inhabitant and the architecture. This reciprocal relationship defines human architecture, which understands time not as linear passage but as an internal process enacted in the body and felt through sensation. To deepen our understanding of this temporal mediation, we can draw on several theoretical frameworks:

Phenomenology of Dwelling: In *Building, Dwelling, Thinking* (1971), Martin Heidegger describes dwelling as a mode of being that unites space and time in a lived horizon. Architecture, he argues, creates a “clearing” where life's rituals—past, present, and future—can authentically unfold.

Genius Loci and Topophilia: Christian Norberg-Schulz's *Genius loci* (1979) and Yi-Fu Tuan's *Topophilia* (1974) emphasize the affective bonds people form with place. By respecting a site's climate, topography, and cultural narratives, architects can foster environments that resonate with collective memory and belonging.

Rhythmanalysis: Henri Lefebvre's *Rhythmanalysis* (1992) reveals urban life as overlapping temporal flows—commutes, markets, festivals. Designing in harmony with these rhythms can transform city squares and corridors into temporal mediators, shifting their use and meaning throughout the day.

Hauntology and Palimpsests: Jacques Derrida's concept of hauntology (1993) reminds us that the past continually "haunts" the present. Exposing patinated brickwork or ghost signage allows buildings to bear witness to their own biographies, inviting occupants to inhabit both "here and now" and "there and then."

Meshwork of Dwelling: Tim Ingold's dwelling perspective (2000) frames architecture as a meshwork of materials, movements, and memories—open systems co-created through acts of making, using, repairing, and remembering. This approach dissolves the boundary between object and event, emphasizing temporal continuity.

Collective Memory: Maurice Halbwachs's theory (1950) posits that memories are socially constructed within shared spaces. Monuments, community centers, and public squares thus scaffold communal narratives, enabling their enactment and transmission across generations.

Together, these perspectives affirm that architecture is an ongoing choreography of perception, memory, and material presence. By weaving phenomenology, sensory engagement, place-making, rhythm analysis, hauntology, meshwork, and collective memory into design practice, we acknowledge that every act of building is also an act of time-making—inviting inhabitants into richer, more layered experiences of living space.

Embracing Temporality: Towards a Humane Architecture

In the contemporary moment—defined by rapid technological change, climatic upheaval, and shifting social patterns—architecture confronts a profound challenge: to remain meaningful and responsive in a world where the only constant is flux. Traditional models of building as static, monumental interventions no longer suffice. Instead, a temporally attuned practice must place time at the very core of design, recognizing

buildings and cities as evolving systems in which past, present, and future coexist dynamically. Through integrating temporality as a design imperative, acknowledging the city as a dynamic palimpsest, and cultivating shared memory and belonging, we can forge an architectural approach that is resilient, humane, and deeply rooted in place.

Temporality as Design Imperative

Conventionally, architecture has been conceived as the creation of enduring objects—structures meant to outlast their inhabitants, symbolizing permanence and stability. Yet this object-centered view obscures the reality that buildings exist within temporal ecologies: materials weather and degrade, programs shift, and communities evolve. To address this, architects must adopt a systems perspective, treating buildings as living organisms rather than static monuments. This shift begins at the earliest design stages, when questions of assembly, adaptation, and obsolescence inform every choice of form, material, and connection.

A principal strategy for embedding temporality is modularity: designing with discrete, standardized components that can be reconfigured, replaced, or expanded without wholesale demolition. Whether through prefabricated wall panels, demountable partition systems, or plug-and-play building services, modular assemblies allow structures to adapt to changing spatial requirements—office to classroom to residence—with minimal waste.

Complementing modularity is the use of reversible connections—mechanical fasteners, dovetail joints, and dry-assembly techniques—that facilitate disassembly and material reuse. This lifecycle approach not only reduces embodied energy but also embeds a legacy protocol within buildings, ensuring that future stewards understand how to transform or deconstruct the structure at end-of-life.

Beyond physical systems, temporality demands the specification of legacy protocols—formal guidelines for lifecycle management that become part of a building’s as-built documentation. Such protocols clarify which elements are intended for adaptation, which materials should be salvaged, and how new interventions can respect existing fabric.

Additionally, buildings can incorporate flexible infrastructures—raised floors for access to utilities, overhead service spines, and adjustable daylighting systems—that anticipate future technological upgrades. By conceiving architecture as an evolving platform, we ensure that structures remain vital and relevant even as functional demands shift over decades.

The City as Dynamic Palimpsest

Cities, like buildings, are rarely blank slates. They accrete layers of physical construction, social practice, and collective memory, forming complex palimpsests in which vestiges of past eras persist alongside new interventions. Recognizing the city as a dynamic palimpsest means acknowledging that every new development writes over—but never fully erases—what came before.

Rather than imposing rigid master plans that attempt to overwrite historical textures, planners must engage with existing strata: the informal street markets, the artisanal workshops, the community murals and graffiti that animate urban life.

A palimpsestic approach privileges incremental, bottom-up interventions that complement larger strategic visions. Tactical urbanism—pop-up plazas, parklets, and open-air galleries—demonstrates how small, temporary installations can catalyze civic engagement and test new uses for underutilized spaces. In Tirana, for example, temporary cultural pavilions along the Lana River invited residents to reimagine a neglected waterway

as a site for performance and gathering. Such interventions are not mere stopgaps; they serve as live experiments, informing more permanent enhancements while fostering local ownership of public space.

While spontaneous acts of urbanism energize neighborhoods, they must operate in dialogue with strategic master plans that safeguard equitable access, environmental resilience, and infrastructural coherence. Master plans can designate zones for high-intensity development, set ecological corridors, and allocate resources for social services—yet within this framework, they should allow for surprise and spontaneity. By codifying flexibility—through adaptive zoning, performance-based regulations, and open-ended design parameters—cities can host a polyphony of urban tactics without sacrificing long-term sustainability.

Cultivating Shared Memory and Belonging

Architecture's power lies as much in its emotional resonance as in its functional utility. Material patina—the weathered surfaces, faded paint, and worn edges that accrue over time—imbue buildings with narratives of use and memory. Instead of stripping these patinas in favor of pristine facades, designers can preserve traces that anchor inhabitants to the building's history. Renovations might leave select walls unrepaired or salvage original flooring, allowing residents to glimpse the past in the present.

To further embed shared memory, projects can incorporate participatory design rituals that invite communities to contribute artifacts, stories, and personal inscriptions. Whether through community-run workshops that design mosaic murals or through “memory walls” where residents post photographs and notes, architecture becomes a canvas for collective storytelling. Such rituals not only foster social cohesion but also ensure that the

building's evolving form is co-authored by those who inhabit it, reinforcing a sense of ownership and belonging. Beyond individual projects, urban design can prioritize community nodes—libraries, community centers, small parks—that act as scaffolds for social networks. By programming these nodes with flexible, multi-use interiors and calendar-driven events (markets, performances, festivals), cities create temporal anchors where shared experiences accumulate. Over time, these nodes become reference points in communal memory—places where generations gather, where rites of passage unfold, and where civic identity is enacted.

reflection

third volume Tirana Architecture Triennale Vol. III

Reflection, unfolds as an experimental, curatorial, and research-based platform dedicated to exploring future emergencies through new design methodologies, participatory processes, and interdisciplinary approaches. This edition centers on the concept of Future Intelligence—a renewed way of understanding and acting upon complex urban realities by combining technology, cultural sensitivity, and the reading of invisible spatial conditions.

Structured around three thematic diptychs, this volume is shaped through workshops, residencies, and a series of public talks that engage artists, curators, researchers, students, and emerging professionals. Each diptych investigates a duality between what is virtually present and physically invisible, addressing the interrelation of space, memory, materiality, and speculative architectural thinking.

Maintenance as Collective Practice exploring care and repair in public space as acts of architecture and everyday agency.

Ruins as Creative Potential reframing urban debris and remnants as sources of ecological and constructive imagination.

Harvest as Cultural Activation traditional and artisanal practices as tools to shape identity and architectural expression.

At its core lies a research and curatorial residency, where a selected curator develops the conceptual framework for the next edition of the Triennale. This process is informed by previous fellows' research, rather than serving as an interlude, Reflection functions as a space of critical thinking, experimentation, and preparation—a site where emerging forms of Future Intelligence are tested, discussed, and projected into new architectural futures.

**TIRANA ARCHITECTURE
TRIENNALE**



nothing is lost nothing is created everything is transformed

residency workshop
Community Maintenance Club
Ania Vang-Anh Tran, Rosy Wing Nga Tam, Spike Zhuo Chen
local collaborator: Saimir Shtylla, Bora Malko



In a world that often equated brokenness with disposability, this workshop challenged the stigma surrounding reuse and embraced repair, celebrating the act of maintenance as a form of care embedded in the urban fabric.

The workshop invited participants to explore the concept of repair and design tools for repair in the city of Tirana. Students took on the roles of repairers, as well as designers, constructing 1:1 mobile repair stations with salvaged, used or waste materials from the university campus. Through experimentation and collaboration, the group established new DIY repair scenarios, developing tools and facilities to form a citywide infrastructure.

MATERIAL AUDIT	
CODE	WOOD/003 RATING A A A
DESCRIPTION	BROWN WOOD PIECE
LOCATION	I.B.C
QUANTITY	2x
DIMENSIONS (mm/ UNIT)	75x 75x 1.7m
COMMENTS	USABLE.



MATERIAL AUDIT	
CODE	WOOD/004 RATING A A A
DESCRIPTION	WHITE WOOD PIECE
LOCATION	I.B.C
QUANTITY	
DIMENSIONS (mm/ UNIT)	120.5 ₂ x 30.1 x 2m
COMMENTS	



Students collectively designed and constructed a glass block shelf that served as a partition and intermediate material store, and a mobile repair cart that transports materials and contains a tool library.

The repair cart served as a gathering point when parked in the community. At the end of the workshop, the group took the mobile repair station out for a test ride in the Selitë neighbourhood.









The workshop invited participants to explore the concept of repair and design tools for repair in the city of Tirana. Students took on the roles of repairers, as well as designers, constructing 1:1 mobile repair stations with salvaged, used or waste materials from the university campus.

Through experimentation and collaboration, the group established new DIY repair scenarios, developing tools and facilities to form a citywide infrastructure. Students collectively designed and constructed a glass block shelf that served as a partition and intermediate material store, and a mobile repair cart that transports materials and contains a tool library. The repair cart served as a gathering point when parked in the community. At the end of the workshop, the group took the mobile repair station out for a test ride in the Selitë neighbourhood.

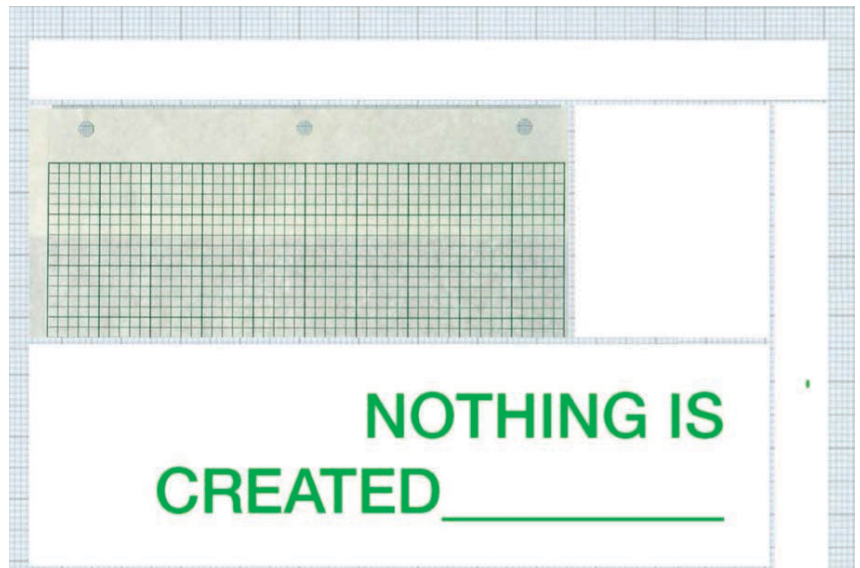



precious materials & processes

transforming plastic 1:1

residency workshop and exhibition
Irena Übler
local collaborator: Iris Nela



“A Broken Circle” marked a powerful culmination of the PRIMA MATTERS design research residency by Irena Übler. The event brought attention to the urgent relationship between consumption, pollution, and the potential for regenerative design—particularly in Albania, where the environmental impact of plastic waste is increasingly visible. Workshop: Transforming Waste into Design On April 10, students from the Interior and Product Design program (1st and 2nd year) at Barleti University participated in an intensive, hands-on workshop led by designer and researcher Irena Übler, supported by Iris Nela, assistant lecturer and department coordinator. The workshop introduced students to the PRIMA MATTERS methodology—a practice of transforming local plastic waste into innovative design objects. Focusing on material experimentation, students learned to sort, shred, and compress plastic residues, especially from water bottle caps and shampoo containers, turning them into thin, layered sheets. These were then used as a canvas for line drawings, material manipulations, and spatial studies inspired by architecture and interior design. Beyond technique, the workshop emphasized critical thinking on circularity, prompting students to explore the lifecycle and meaning of everyday waste. Exhibition: «Precious Materials & Processes» The outcomes of the workshop were presented in a bold collective installation titled “Precious Materials & Processes”, unveiled on April 10 at Barleti University. The centerpiece was a suspended lighting object, designed and produced using a

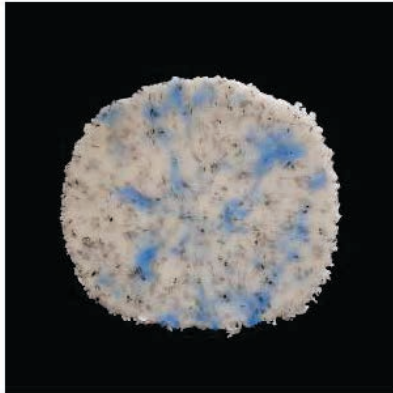
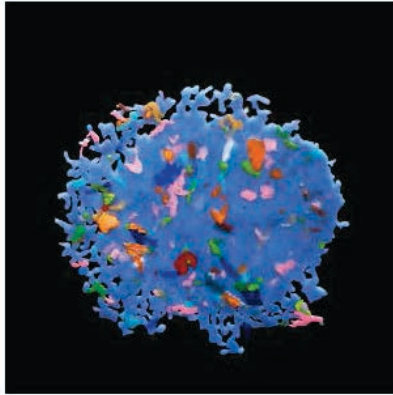
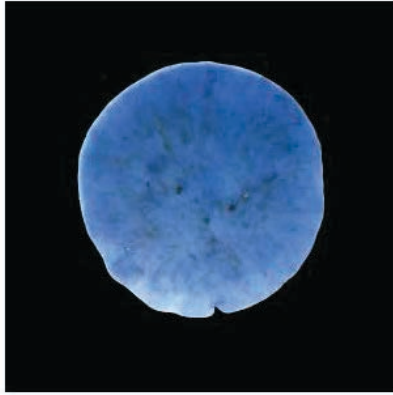

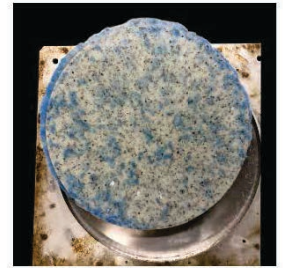
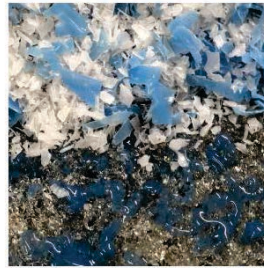
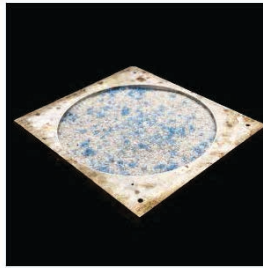

combination of 30% Albanian blue bottle caps and 70% semi-transparent shampoo bottles. Manufactured via compression molding and finalized on a lathe, the lamp was both symbolic and functional—a luminous synthesis of resourcefulness and critique. The exhibition narrated a deeper story: Albania's bottled water culture produces thousands of plastic remnants daily, yet less than 17% of plastic waste is recycled—far below the European average. The lamp, made entirely of recycled plastic, reflected this tension. It brought together the acts of hydration and hygiene with the unintended consequence of pollution, asking: What if plastic could become treasure? Narrative Focus: Water and Waste The installation operated as a material manifesto,

highlighting the contradiction at the heart of modern consumption: the same water we rely on for survival leaves behind a trail of waste that threatens our ecosystems. By giving new form to this contradiction, the project invited viewers to reflect on how regeneration can begin with the things we touch every day. The objects and processes on display emerged as new narratives of sustainable design in Tirana, grounded in local waste streams but resonating globally. The workshop and exhibition were developed in collaboration with the LINA Community, Barleti University, and the Austrian Embassy in Tirana, with the support of the international design project PRIMA MATTERS.



stitch

residency workshop and exhibition
Rubble - Nicolas Howden, David Hurley
local collaborator: Etleva Dobjani, Laura Shumka, Iris Elezi

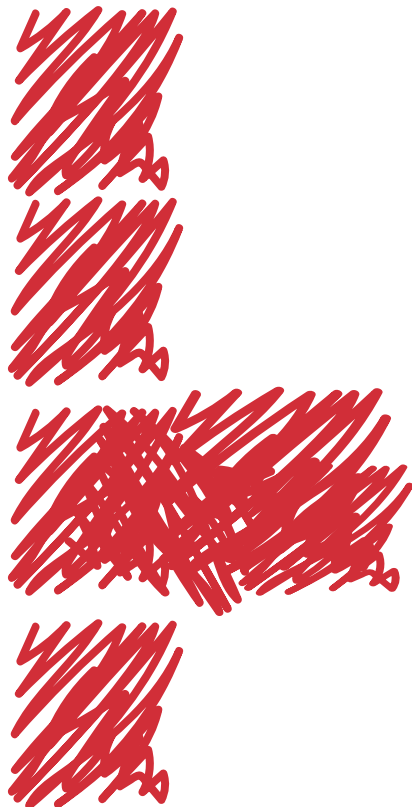

The Stitch Workshop was a collaborative construction workshop held in partnership with Barleti University and The Albanian Cinematheque at the Silikati Factory in Kombinat, Tirana, Albania. The main objective of the workshop was to design and create a series of minor architectural interventions for The Albanian Cinematheque, utilizing materials sourced from the on-site Silikati Factory.

Students were introduced to the concept of working within peripheral, post-industrial spaces and guided through a series of exercises that allowed them to explore how to intervene meaningfully in these types of environments. The workshop emphasized the creation of alternative cultural spaces within a post-industrial context, which is a particularly timely and relevant topic for Tirana's urban development. This hands-on engagement provided the students with the opportunity to practically address the challenges and potential of these spaces, fostering a creative exploration of architectural possibilities.

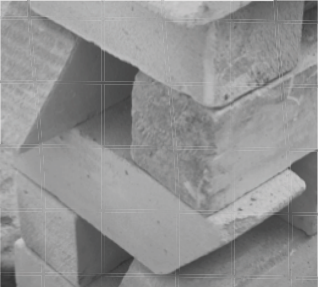



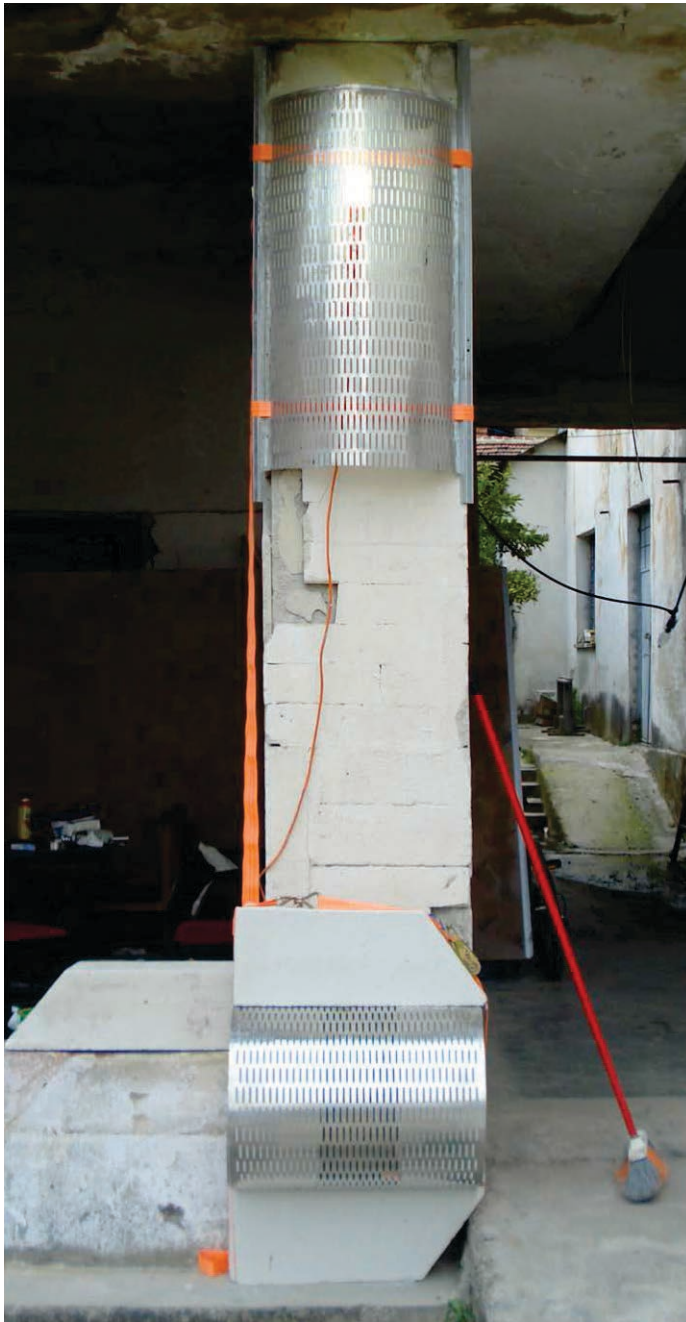

A secondary, personal goal of the workshop was to foster closer relationships between the participants, Barleti University, and Iris Elezi, who runs The Albanian Cinematheque. Iris's family owns and manages the Silikati Factory and its artistic and creative rental spaces. Through her interest in connecting the workshop organizers with the factory's workers and broader network, the initiative gained valuable insight into the local context. As a result, the workshop participants were invited to screenings at Vila 31, where they were able to learn about Iris's curatorial work and vision.

This collaboration has set the stage for deeper future partnerships and the intention to seek funding for a larger, more expansive project in the near future, further exploring the intersection of culture, architecture, and post-industrial spaces in Tirana.





ups_urban placemaking soup

residency workshop and exhibition
Harvest Saloon - Livni Holtz, Nicolas Seiler, Sebastian Reinicke
local collaborator: Hekuran Bendaj



The workshop focused on the intersection of digital service infrastructures, such as delivery apps, ride-hailing platforms, and freelance tourism guidance systems, and the urban landscape of Tirana. It sought to investigate how these systems shape labor, time, and space within the city and how they can be made visible and open to reimagination.

Over six days, second-year architecture students from Barleti University engaged in an immersive, multidisciplinary process combining fieldwork, documentary filmmaking, and urban analysis. The participants were tasked with exploring how the gig economy impacts the city's public space and urban rhythm, shedding light on the invisible labor forces that power the digital services shaping daily life in Tirana.

Day 1 – Tools, Positions, and Modes of Documentation
The workshop began with an introduction to various forms of documentation, where participants brought objects from their personal lives that they associated with storytelling. This provided a reflective starting point on how to position oneself within the ethnographic process. The day then shifted to an analysis of documentary filmmaking strategies through three reference films: *The Girl Chewing Gum* by John Smith, *Inextinguishable Fire* by Harun Farocki, and *The Gleaners and I* by Agnès Varda. These films provided a foundation for understanding the ethical, formal, and political implications of documentary filmmaking in urban research.









On the second day, students mapped the digital footprint of platforms like delivery services and ride-hailing apps, paying attention to the invisible rhythms of gig work—moments of waiting, searching, and algorithmic pauses. Fabio Hofrath’s lecture elaborated on the conditions of digital labor, its gamification logic, and how it conditions behavior within urban space. Participants then began conceptualizing their short films, considering how their films would investigate the intersection of platform labor and public space in Tirana.

The third day was dedicated to fieldwork, where participants went out into the city to film. Some followed gig workers as they navigated their daily routes, while others engaged in conversations at waiting zones or focused on micro-sites influenced by the invisible presence of platforms. The participants explored their visibility and positionality in these encounters, considering when to intervene or remain passive. This stage was characterized by experimentation and real-time feedback, with students learning to approach filmmaking as an inquiry tool, capturing the lived experience of gig workers.





cr

cr

cr

cr

cr

cr

qr

qr

qr

qr

qr

qr

or

or

or

or

or

or

tr

tr

tr

tr

tr

tr





After gathering field footage, participants began editing their films on Day 4. They were introduced to the editing software DaVinci Resolve and guided through the ethical and discursive choices that come with the editing process. Editing decisions such as cuts, pacing, and narration were discussed, highlighting how these choices shape the final narrative. A peer feedback session allowed for constructive critiques, and students refined their films with additional perspectives in mind.

On the final day, students worked to complete their films, refining their edits, adding sound design, and incorporating any last-minute changes. A final collective reflection and screening of the films took place in the afternoon. The films were presented in a casual format, and discussions followed on how each group had navigated fieldwork, storytelling, and ethical complexities. Rather than focusing on polished results, the screening emphasized the process of engagement and the stories that emerged from it.





The UPS – Urban Placemaking Soup workshop was a practice-led exploration of how digital labor platforms influence urban life, focusing on the hidden realities of gig workers in Tirana. The workshop adopted documentary filmmaking as a tool for inquiry, allowing participants to shift their perspective of the city from a static object to a dynamic, living environment shaped by digital infrastructures and human interactions.

Rather than imposing architectural solutions, the participants used their films to explore alternative relationships to public space, showing how gig labor, moments of waiting, and informal gatherings redefine the urban experience. The workshop successfully bridged the gap between urban analysis, film, and placemaking, with the final films serving as thoughtful responses to the invisibility of platform labor. Through these explorations, the students contributed to a broader understanding of the intersection between digital economies, public space, and human connection.

Architectures
of the Invisibles
Margins and
Beyonds
Tirana
Architectures of
the Invisibles
Margins and
Beyonds
Tirana
Architectures of
the Invisibles
Margins and
Beyonds
Tirana

architectures of the invisible

Between Margins and Beyond in Tirana
Tirana Architecture Triennale 2026
Andreia Garcia

Tirana is not merely a visible city. Its territory is composed of the visible but also of invisible layers of underground flows and flooded landscapes, of remnants and reconstructions. Within its streets, hills, and buildings, pulses an invisible reality that profoundly shapes how it is inhabited, built, and imagined. The Tirana Architecture Triennial 2026 proposes itself as a collective essay on the architectures of the invisible — structures, systems and subjectivities that operate at the margins of visibility and normativity. This context invites us to rethink architecture not as a formal or functional response, but as a speculative and sensitive practice — one that excavates, absorbs and reflects.

Inspired by Emanuele Coccia and his understanding of the city as a «vital medium» (2018), the proposal for this Tirana Architecture Triennale edition broadens its focus to what is not seen: subterranean water flows, historical sediments, peripheral gestures of daily survival, knowledges never archived but still resonant in the interstices of the urban fabric. It is in the invisible where, paradoxically, the widest field of possibility lies.

This curatorial approach is shaped by the tension between the concepts of undercity and underwater, exploring Tirana as a living, porous, and mutating body. The architectures of the invisible are here understood as speculative, sensitive, and reparative forms that operate between the visible and the latent. As Tirana positions as an urban laboratory for ecological and social transition in Southeastern Europe, our aim is to engage with what is not immediately visible: aquifers

and hydrological systems that sustain (or threaten) the urban fabric; construction waste and surplus; peripheral and informal ways of living that resist normative planning logics; non-human knowledge inscribed in the living matter of the landscape.

Structural and Poetic Invisibilities

As argued by Pedro Gadanho (2022) and Paola Antonelli (2019), architecture today must move beyond formal or technological response - it must reinvent itself as a critical and reparative practice. The curatorial proposal for Tirana Architecture Triennial 2026 aligns closely with Pedro Gadanho's conception of architecture as a critical and political act. It advocates for spatial practices that engage with ecological and social urgencies, particularly within fragile or transitional contexts. At the same time, echoing Paola Antonelli's assertion that architecture and urbanism must transcend mere contextual responsiveness, this approach positions design as a transformative mediator. By invoking the imaginary of the undercity and the underwater, it brings to the surface the often-concealed fractures between urban systems and ecological processes, calling for an architecture that listens, that heals, and that reimagines—an architecture of care, repair, and speculation. In the context of Tirana — where the city emerges between underground flows, debris, and improvised settlements — it is vital to develop spatial strategies that are at once ecological, speculative, and activist. At the same time, a provocative counterpoint to critical ecological approaches can be found in the ecomodernist thought. The Ecomodernist Manifesto claims that “the requirement that humans use their growing social, economic, and technological powers to make life better for people, stabilise the climate, and protect the natural world” (Breakthrough Institute, 2015, p. 3) is both viable and desirable. From this perspective, the Anthropocene is not a problem to be reversed but an opportunity to be managed with technical efficacy. The intensification of human

activities — especially in agriculture, energy, and urbanism — would, according to this vision, lead to an increasing decoupling between human development and environmental impact, through reduced land appropriation (Breakthrough Institute, 2015, p. 9).

Where Morin sees complexity and relationality as inseparable from ecological regeneration (Morin, 1991, pp.10-11), ecomodernists view the future as lying in a technoscientific fast forward. Their defence of nuclear energy as a clean and dense resource strengthens this proposition (Breakthrough Institute, 2015, p. 18). This dichotomy is particularly relevant in the Albanian context, where post-socialist urban development has oscillated between large-scale infrastructures and informal popular practices. Integrating this critical tension into the Triennial means considering not only sensitive ecological visions but also pragmatic approaches that acknowledge the inevitability of environmental transformation — possibly via advanced technology.

Although the curatorial proposal of this Triennial privileges sensitive, slow, and situated methodologies, it is necessary to engage with this pragmatic strand of environmental thinking. A position that finds resonance, albeit from a different perspective, in James Lovelock's Gaia theory. For Lovelock, the Earth and life form a single, closely linked system in which nothing happens by chance and in which human actions — including technological ones — are integrated into a greater systemic regulatory logic. "Whether we like it or not, and regardless of what we do to the global system, we will continue to be drawn, perhaps without realising it, into Gaia's regulatory process" (Lovelock, 2006, p. 148). From this perspective, human action is inevitably part of a self-regulating whole, and even the vast destructions caused by industrial societies are relativised when compared with the natural devastation of phenomena such as the ice ages. Lovelock argues that periods of rapid technological development — such as the





discovery of fire or our current moment — should not be seen merely as environmental threats, but as profound reorganisations of the relationship between humanity and the planet.

The confrontation between these epistemologies will enrich the debate this Triennial intends to foster. And if Lovelock's vision may well be valid within the logic of Gaia as a resilient planetary system, it seems, paradoxically, to underestimate the dimension of human intelligence — our mental and social ecology — which reminds us of the responsibility we bear, at the very least, for one another. To further enrich this epistemological landscape, voices such as Naomi Klein or Isabelle Stengers could be brought into the conversation — Klein by emphasising the political economy of ecological disaster and climate inaction (2014), and Stengers by challenging scientific authority and proposing alternative modes of knowing and resisting (2015). Their perspectives help complicate the dualism between technological optimism and geopolitical retreat, introducing critical attention to capitalism's role in shaping environmental futures.

This is where Bruno Latour becomes an indispensable interlocutor (2018). In his book *Down to Earth*, Latour argues that we have entered a new climatic regime in which collective action has been replaced by strategies of withdrawal. For many — particularly the most powerful — it is no longer about building a common future, but about protecting their own ground and resources, even if that means abandoning the idea of a shared horizon. “There is no room on Earth for everyone,” Latour asserts (2018), drawing attention to the growing inequality imposed by a global system that favours the unequal appropriation of land and ecological rights. Thus, while Lovelock may be mobilised to justify a certain technological passivity in the face of environmental collapse, Latour calls for reaction, repositioning, and political imagination.

The invisible in architecture refers not only to what is buried or concealed, but also to what has been deliberately excluded: informal populations, vernacular knowledges, more-than-human relations, and processes that elude hegemonic planning systems. This Triennial seeks to map these invisible layers and bring their agents to the forefront of the architectural debate

The proposal also draws upon Edgar Morin's essay *The Lost Paradigm: Human Nature*, a foundational text for ecological thought in the 1970s. Morin questions the Cartesian paradigm that opposes human beings to nature, deconstructing the modern conviction that nature is something to be dominated, exploited, or subdued. Instead, he proposes a more complex conception of the totality of living beings, recognising that indeterminacy, disorder, and chance are also forms of organisation and intelligence. This reading allows us to rethink Tirana's urban ecologies not as systems to be stabilised, but as organisms in becoming, where the invisible is an integral part of vital dynamics.

“The ecosystemic relationship is not an external relation between two isolated entities; it is an integrative relation between two open systems, in which each is part of the other, although each constitutes a whole: the more autonomous a living system is, the more dependent it is on the ecosystem. [...] The human individual, which is the ultimate flower of this complexity, is at once the most emancipated and the most dependent on society” (Morin, 1991, pp. 10–11).

In his book *We Are the Weather*, Jonathan Safran Foer raises a disturbingly relevant question: why, despite all this evidence and these alternatives, do we still fail to act? According to the author, there is a distance between perception and feeling that prevents us from acting with urgency. Rationally, we know we are heading towards climate collapse, but we do not truly

feel it. There is a kind of emotional and symbolic blockage that prevents information from being transformed into action. Perhaps, Foer suggests, we unconsciously cling to irrational hope, to an internalised refusal to accept the end (Foer, 2020).

This intimate analysis of contemporary collective behaviour complements and problematises more abstract philosophical approaches. In a distinct yet equally mobilising register, the figure of Greta Thunberg introduces a radical and uncompromising ethical appeal. Her activism directly confronts global political and economic structures with disarming clarity: “I want you to panic. I want you to act as if you would in a crisis. I want you to act as if our house is on fire — because it is” (Thunberg, 2019).

Greta operates in the space between knowing and feeling with a kind of moral urgency that refuses postponement. In contrast to the irrational hope denounced by Foer, Thunberg insists on concrete action as a way of rejecting collapse. Her message reveals not only the inertia of power systems but also the transformative potential of a shared ethical consciousness — a politics that does not merely map the invisible but agitates it until it is revealed.

The curatorial proposal of this Triennial embraces this tension: between reason and emotion, between knowing and feeling, between architecture as a practice of hope and as a witness to what is about to disappear.

Between Lovelock’s quasi-theological optimism and Latour’s geopolitical pessimism, a point of convergence emerges: both critique the Cartesian legacy that separated mind and body, culture and nature, city and biosphere. From this perspective, the city ceases to be a stage for instrumental reason and becomes a sensitive ecosystem, where human and non-human beings coexist and co-produce space. The dichotomy between nature and culture,

between human and animal, between artefact and environment, is here dissolved in favour of a relational and regenerative approach.

Other ecological and philosophical thinkers help to expand this vision. Donna Haraway introduces the concept of composting as a way of thinking about living-with: “Staying with the trouble,” for Haraway, is about accepting the pain, complexity, and uncertainty of collapsing worlds, and learning to live and die well with others (both human and non-human) (2016).

Likewise, Timothy Morton advocates the idea of dark ecology, in which proximity to ecological crisis demands an intimate coexistence with the strange, the toxic, and what modern thinking has rejected (2007).

At the confluence of Morin, Haraway, Morton, and Latour, this curatorial proposal understands the invisible not merely as the unseen, but as the unacknowledged: that which lies outside the framework of dominant epistemologies and is, for that very reason, fertile and urgent.

Echoing the spirit of the academic Medi Tirana project (2024), this edition of the Triennale does not aim to import models or idealise solutions. Rather, it embraces situated forms of knowledge — arising from the underground, from water, from the peripheries — to understand how the city may be inhabited more justly, more sensitively, and more resiliently. Tirana is envisioned as a site of tension between planned and improvised city-making, between the memory of the plain and the speculation of verticality. It is, above all, a testing ground for forms of architecture that do not impose, but listen. As Lefebvre proposed (1968), the right to the city must be extended to those who do not appear on plans

or maps — yet who build it with their gestures and survival. This curatorial proposal listens to underground voices and emergent practices that, while absent from the official plans, echo Lefebvre’s vision: informal inhabitants, unmapped systems — of water, waste, animals, and local knowledge — all claim the right to influence the city’s present and future, not as passive users, but as authors of urban space..

Bringing together agents working across architecture, ecology, art and politics — many already embedded in marginal territories or threatened environments — we aim to map strategies of resistance and care: circular infrastructures, adaptive informal architectures, resilient community markets, reuse of materials, and urban design processes that learn from water, soil, and animal intelligence. The 2026 Triennale thus seeks to be a space for listening to the underground — whether composed of waters, waste, silenced voices, or architectures in waiting. It is in the margins and interstices that the future of the city will be designed. To give structure to this curatorial project, three thematic axes are proposed.

Three Axes for Investigation

The three lines of enquiry do not represent fixed categories, but rather fluid territories for research and experimentation. Each axis seeks to illuminate how the invisible manifests in urban, ecological, and affective dimensions — offering ways to think, draw, and build otherwise, particularly in response to the hidden ecologies, informal infrastructures, marginalised voices, non-human agencies, and alternative spatial imaginaries. They arise from the curatorial commitment to engage with the invisible not only as an abstract notion, but as a lived condition — one that manifests in the social, ecological, and affective fabrics of Tirana.

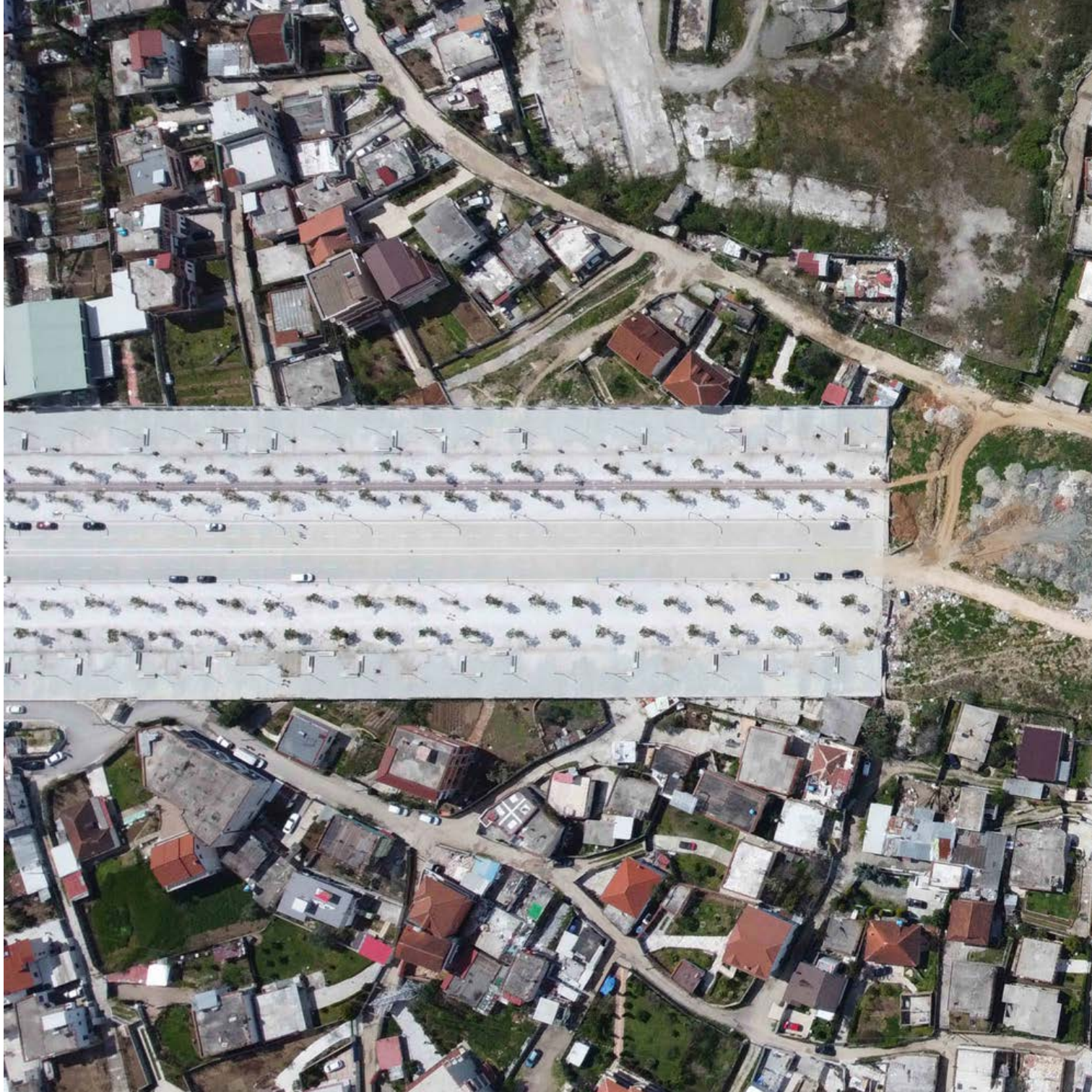



Porous and Interstitial Architectures

This axis explores spatial practices that respond to fragmentation, permeability, and ambiguity in the urban environment. Drawing on theories of complexity, it proposes that the in-between is not a void but a generative space where architecture can unfold with flexibility and openness. These are contexts that resist rigid zoning, top-down infrastructure, or fixed typologies — favouring instead architectures that learn from informality, nature, and improvisation.

Practices that emerge in the “in-betweens” — between the natural and the artificial, the planned and the spontaneous. These are interventions that absorb uncertainty, work with instability, and recognise indeterminacy as a space of projective freedom.

Inspired by Morin’s notion that complexity is built upon chance, disorder, and error, these architectures reject functional homogeneity and affirm the right to failure and adaptation. They echo infrastructural experiments and spatial reconfigurations that challenge visibility, such as transforming vehicular spaces into communal grounds, reclaiming public voids, or performing artistic interruptions within rigid bureaucratic structures.





Invisible Cycles: Bodies, Waste, Time

This axis investigates how the flows of waste, bodily presence, and temporal rhythms — often neglected in architectural discourse — shape space and meaning. Architecture is not only static structure but a metabolic interface: it absorbs, circulates, and discharges matter and memory. Here, the invisible is understood as cyclical and corporeal, embedded in habits of disposal, rituals of care, and non-linear temporalities.

Marginal matter, often invisible to traditional architectural observation, becomes the protagonist. Waste is treated as resource; bodies as archives; time as circular. This is an architecture that metabolises the discarded and restores to the architectural gesture its capacity for reinterpretation.

The recognition of circularity, again echoing Morin, introduces an ecological thinking that values cycles of transformation over productive linearity. These insights find resonance in grassroots recycling networks, experimental ecological infrastructures such as constructed wetlands, and citizen-led conservation efforts that defend fragile ecosystems at the urban margins. Together, they expose and rework the metabolic undercurrents of the city.





Speculative and Affective Cartographies

This axis addresses how space can be reimaged through affect, memory, and projection. Rather than mapping what exists, these practices trace what is felt, feared, or desired — proposing fictions as tools for critical engagement. Drawing from feminist theory, environmental humanities and artistic research, these cartographies resist neutrality. They foreground emotional geographies and contested narratives that expand architectural imagination.

The invisible is also that which is dreamed, remembered, and felt. Here, the project is proposed as critical and affective fiction, capable of imagining alternative realities. The body, memory, and desire become design tools. As Morin suggested, intelligence is not only analytical rationality but also imagination, emotion, and empathy. These speculative cartographies therefore propose new ways of knowing and designing.

A particularly resonant example of this is the work of Forensic Architecture, which uses spatial analysis, digital reconstruction, and testimony to render visible state violence and structural erasure. Their approach transforms architecture into a form of evidence and activism — mapping absence and presence through affect and space. Similarly, Cooking Sections has employed food systems and climate change narratives to curate immersive, sensorial cartographies — blending site, culture and ecological urgency. These examples illustrate how speculative and affective cartographies can reframe both knowledge and agency in contemporary spatial practice.

From digital archiving of ephemeral artistic practices to community storytelling, and grassroots mapping of informal territories and endangered species, all function as speculative tools that make visible what institutional narratives often ignore.



Voices from the Territory

The curatorial questions of the Triennial find their most grounded responses in local practices that operate at the threshold of visibility — in neglected infrastructures, in marginal ecologies, in minor gestures of resistance and care. These are not monumental interventions, but situated actions that speak through reclaimed wetlands, reused materials, informal networks, and ephemeral performances. They reveal how the city is continuously reimagined through what is absent from its maps: waste, silence, memory, and improvisation. These voices — of researchers, educators, artists and inhabitants — not only exemplify the themes of the Triennial, but give them life, urgency, and continuity. They remind us that architecture, in its most essential form, is not just about building but about listening, remembering, and restoring. These initiatives, deeply rooted in the Albanian context, do not aim for visibility as validation. Instead, they insist on presence through practice — by restoring forgotten spaces, contesting exclusions, sustaining biodiversity, or reconfiguring participation. They enact as a form of architecture that is not simply constructed, but assembled through listening, activation, and refusal. In doing so, they make tangible the invisible forces — ecological, social, and symbolic — that shape urban life in ways both precarious and generative. It is these quiet, grounded architectures that will form the core of the next Triennial — an ecology of significant gestures.

To engage with these voices is to accept the city not as a finished form but as a continual negotiation between what is seen and what is made unseen. These case studies are not intended as fixed models or blueprints. Rather, they act as resonant fragments — grounded, plural, and open-ended. They embody the invisible through diverse tactics: from occupying neglected infrastructures to regenerating waste, from mapping informality to revitalising affective memory or protecting endangered species. While these examples demonstrate methods and strategies, it is in the lived voices of the territory where architecture's ethical



and affective power fully emerges. Here, the invisible speaks — through testimony, pedagogy, memory, and transformation. It is to understand architecture as method and mediation — a political, ethical, and imaginative act rooted in the peripheries of urban experience. These contributions — practices that operate on the margins of visibility engaging with forgotten territories and social ecologies —, while specific to Tirana, resonate far beyond, offering critical models for how invisibility can become a tool for reparation, resistance, and reinvention.

The three conceptual axes previously presented invited us to look beyond the theoretical, into the grounded practices that embody and activate the invisible in Tirana today. What follows are concrete examples — fragmentary yet resonant — where these ideas find spatial, social, and ecological form: from informal housing networks to circular economies, from artistic resistance to biodiversity protection, from wetlands to pedagogical experiments: A Curatorship of the Invisible

These reflections lead us back to the curatorial position. What does it mean to curate the invisible? Not merely as a theme, but as a method, an ethic, and a horizon of practice — capable of unsettling dominant logics, informing public policy, and reconfiguring our understanding of urban space.

Rather than presenting itself as a curatorship of the underground, this Triennial proposes a curatorship of the invisible — of that

which remains uncounted, unarchived, silenced, intangible, peripheral or residual, yet crucial to the metabolism of the city. The invisible is not absence. The invisible is not synonymous with emptiness; it is a field of latency, resistance, and potential. It comprises both what has been actively suppressed — informal infrastructures, marginal ecologies, erased memories — and what simply escapes dominant categories of recognition. This curatorial vision does not seek to uncover what lies buried, but to reorient our gaze toward what has been deliberately left out — the gestures, narratives and agents that inhabit the gaps between disciplines, systems and imaginaries.

It does not excavate in search of truth but tunes into the background noise of the urban: the slow, the non-spectacular, the relational. It repositions listening, speculation and care as architectural acts. It does not assert visibility as the final goal but affirms that only by taking the invisible seriously can we shape a just and meaningful city. Rather than making everything visible, it asks how visibility can be redistributed — ethically, responsibly, and with political imagination.

Tirana 2026 aspires to be a Triennial that embraces complexity, makes room for contradiction, and cultivates an ethos of situated care. It seeks to imagine the city not as a fixed entity, but as an evolving ecology — a porous, plural, and unfinished process of becoming. Through the activation of voices, gestures, and architectures of the invisible, it proposes to redraw the parameters of what counts as presence, value, and future.



References

- Antonelli, Paola. Broken Nature: Design Takes on Human Survival. Milan Triennale catalog, 2019.
- Breakthrough Institute. Ecomodernist Manifesto. Kotev Editora, 2016 (original 2015).
- Coccia, Emanuele. The Life of Plants: A Metaphysics of Mixture. Cambridge: Polity Press, 2018.
- Foer, Jonathan Safran. We Are the Weather: Saving the Planet Begins at Breakfast. London: Penguin, 2020.
- Gadanho, Pedro. Climax Change!. Barcelona: Actar, 2022.
- Haraway, Donna. Staying with the Trouble: Making Kin in the Chthulucene. Durham: Duke University Press, 2016.
- Klein, Naomi. This Changes Everything: Capitalism vs. the Climate. New York: Simon & Schuster, 2014.
- Latour, Bruno. Down to Earth – Politics in the New Climatic Regime. Cambridge: Polity, 2018.
- Latour, Bruno. Onde Aterror? Como Se Orientar Politicamente no Antropoceno. Lisboa: Antígona, 2019.
- Lefebvre, Henri. Le Droit à la Ville. Paris: Éditions Anthropos, 1968.
- Lovelock, James. A Vingança de Gaia. São Paulo: Intrínseca, 2006.
- Morin, Edgar. O Paradigma Perdido: a Natureza Humana. Sintra: Publicações Europa-América, 1991 (1973).
- MediTirana. Designing Circular Markets. Design Studio Fall'24 Urban Prototyping. ETHZ | Zurich & Barleti University, 2024.
- Morton, Timothy. Ecology Without Nature: Rethinking Environmental Aesthetics. Cambridge: Harvard University Press, 2007.
- Stengers, Isabelle. In Catastrophic Times: Resisting the Coming Barbarism. Open Humanities Press, 2015.
- Thunberg, Greta. Ninguém é Pequeno Demais para Fazer a Diferença. Lisboa: Presença, 2019.



WALLY

SENT

ALLY

RF

PHYSICIAN
INVISIBLE

Toward a Temporally Attuned Practice

Embracing temporality in architecture means reimagining the very relationship between design and its users, shifting away from the notion of the solitary architect as sole author toward a model of collaborative stewardship. In this approach, architects, planners, local authorities, developers, and community members enter into an ongoing conversation that spans the entire lifespan of a building or neighborhood. Instead of delivering a fixed blueprint and stepping aside, design teams now deploy mobile workshops in vacant lots, convert storefronts into pop-up charrettes, and use digital platforms for crowdsourced feedback—all to ensure that the voices of residents, shopkeepers, and informal users help shape and refine proposals in real time.

Meanwhile, “meanwhile” activations—temporary markets, open-air galleries, or street-side reading rooms—offer living laboratories where new ideas can be tested, celebrated, and, if successful, evolve into more permanent solutions. The result is a sense of shared ownership: when people see their suggestions realized, whether through the planting of a community garden or the installation of a parklet on their street, they become active stewards of the places they inhabit.

For this collaborative spirit to thrive, policy mechanisms must also transform. Traditional zoning codes and prescriptive building regulations, once rigid and unyielding, give way to adaptive governance frameworks that can evolve alongside social and environmental change. Rather than mandating specific dimensions or materials, performance-based codes articulate desired outcomes—energy efficiency, walkability, public health metrics—

while leaving room for creative, context-sensitive responses. Pilot zones allow cities to experiment with innovative housing typologies or decentralized energy microgrids, capturing lessons that inform broader legislative reform. Sunset clauses embedded in special permits ensure that temporary uses remain appropriate over time, requiring owners to demonstrate ongoing relevance or apply for new permissions. Even enforcement becomes more dynamic: real-time data feeds from smart-city sensors can alert officials to emerging maintenance issues or shifts in pedestrian patterns, prompting timely regulatory adjustments that keep the built environment in dialogue with its inhabitants.

At the heart of a temporally attuned practice lies a commitment to education that foregrounds time as a design parameter. In the studio, students no longer present a single “final” building, but script multiple life-cycle stages—conception, occupation, decay, and repurposing—negotiating social, economic, and ecological dimensions at each turn. They learn to specify reversible connections alongside anchoring details, plot out deconstruction strategies as rigorously as construction sequencing, and devise “legacy protocols” that future stewards can follow when adapting or dismantling their work.

Coursework integrates perspectives from sociology, environmental science, and data analytics, training young architects to read demographic trends, model climate impacts, and harness real-time performance metrics. Professional development continues this learning beyond graduation, with workshops on circular-economy principles, digital-twin monitoring, and community-

engagement toolkits, ensuring that practitioners remain fluent in time-based strategies throughout their careers. By centering temporality, architecture ceases to be a one-off act of creation and becomes a sustained practice of place-making.

Buildings evolve like organisms, shedding obsolete components and sprouting new functions in response to changing needs. Neighborhoods become living palimpsests, where each layer—be it a century-old warehouse or last season’s pop-up market—contributes to a richer tapestry of memory and meaning. Communities, empowered by continuous engagement and flexible governance, co-author the unfolding narrative of their environments, knitting social fabric through participatory rituals, material patinas, and shared memories. In this way, architecture becomes more elastic—capable of stretching to accommodate new realities—and more humane—rooted in sensory richness and emotional resonance.

Ultimately, a temporally attuned practice does more than shape the physical form of our cities; it nurtures a collective sense of belonging, ensuring that every intervention honors the past, serves the present, and remains open to an ever-emerging future.

References

- Arendt, H. (1958). *The Human Condition*. Chicago: University of Chicago Press.
- Augé, M. (1995). *Non-Places: Introduction to an Anthropology of Supermodernity* (J. Howe, Trans.). London: Verso. (Original work published 1992)
- Bachelard, G. (1957). *La Poétique de l'Espace*. Paris: Presses Universitaires de France.
- Castells, M. (1996). *The Rise of the Network Society* (2nd ed.). Oxford: Blackwell.
- Certeau, M. de. (1984). *The Practice of Everyday Life* (S. Rendall, Trans.). Berkeley: University of California Press. (Original work published 1980)
- Corboz, A. (1983). "Le territoire comme palimpseste." *Diogenès*, 121(1), 14–35.
- Derrida, J. (1994). *Specters of Marx: The State of the Debt, the Work of Mourning, & the New International*. New York: Routledge.
- Derrida, J. (1995). "Archive Fever." *Diacritics*, 25(2), 9–63.
- Derrida, J. (1995). *Points...: Interviews, 1974–1994*. Stanford, CA: Stanford University Press.
- de Certeau, M. see Certeau, M. de.
- Foucault, M. (1977). *Discipline and Punish: The Birth of the Prison* (A. Sheridan, Trans.). New York: Pantheon. (Original work published 1975)
- Foucault, M. (1986). "Of Other Spaces: Utopias and Heterotopias" (J. Miskowiec, Trans.). *Diacritics*, 16(1), 22–27.
- Frampton, K. (1983). "Towards a Critical Regionalism: Six Points for an Architecture of Resistance." In H. Foster (Ed.), *The Anti-Aesthetic: Essays on Postmodern Culture* (pp. 16–30). Bay Press.
- Halbwachs, M. (1950). *The Collective Memory*. New York: Harper & Row.
- Harvey, D. (1989). *The Condition of Postmodernity: An Enquiry into the Origins of Cultural Change*. Oxford: Blackwell.
- Heidegger, M. (1971). "Building, Dwelling, Thinking." In A. Hofstadter (Ed.), *Poetry, Language, Thought* (pp. 145–162). New York: Harper & Row.
- Hägerstrand, T. (1970). "What About People in Regional Studies?" *Papers of the Regional Science Association*, 24(1), 7–24.
- Ingold, T. (2000). *The Perception of the Environment: Essays on*

Livelihood, Dwelling and Skill. London: Routledge.

- Jacobs, J. (1961). *The Death and Life of Great American Cities*. New York: Random House.
- Koolhaas, R. (2001). "Junkspace." In C. Davidson (Ed.), *Obsolescence* (pp. 175–190). Cambridge, MA: MIT Press.
- Latour, B. (2005). *Reassembling the Social: An Introduction to Actor–Network-Theory*. Oxford: Oxford University Press.
- Lefebvre, H. (1991). *The Production of Space* (D. Nicholson-Smith, Trans.). Oxford: Blackwell. (Original work published 1974)
- Lefebvre, H. (1992). *Rhythmanalysis: Space, Time and Everyday Life* (S. Elden & G. Moore, Trans.). London: Continuum.
- Lynch, K. (1960). *The Image of the City*. Cambridge, MA: MIT Press.
- Massey, D. (2005). *For Space*. London: Sage.
- Merleau-Ponty, M. (1945). *Phenomenology of Perception* (C. Smith, Trans.). London: Routledge.
- Moneo, R. (1992). *Theoretical Anxiety and Design Strategies in the Work of Eight Contemporary Architects*. Cambridge, MA: MIT Press.
- Norberg-Schulz, C. (1979). *Genius Loci: Towards a Phenomenology of Architecture*. New York: Rizzoli.
- Pallasmaa, J. (1996). *The Eyes of the Skin: Architecture and the Senses*. Chichester: Wiley.
- Rossi, A. (1966). *The Architecture of the City*. Cambridge, MA: MIT Press.
- Sennett, R. (1977). *The Fall of Public Man*. New York: Knopf.
- Soja, E. (1996). *Thirdspace: Journeys to Los Angeles and Other Real-and-Imagined Places*. Oxford: Blackwell.
- Turkle, S. (2011). *Alone Together: Why We Expect More from Technology and Less from Each Other*. New York: Basic Books.
- Tuan, Y.-F. (1974). *Topophilia: A Study of Environmental Perception, Attitudes, and Values*. New York: Columbia University Press.
- Tschumi, B. (1994). *Event-Cities*. Cambridge, MA: MIT Press.
- Virilio, P. (1997). *Open Sky* (J. Rose, Trans.). London: Verso. (Original work published 1995)
- Wellman, B., & Rainie, L. (2012). *Networked: The New Social Operating System*. Cambridge, MA: MIT Press.
- Zumthor, P. (1998). *Thinking Architecture*. Basel: Birkhäuser.

